



MEMORANDUM

February 28, 2019

**TO:** Erik Wahlquist  
General Counsel, Chelan Public Utility District No. 1

**FROM:** Harold Malkin *HAM*

**RE:** Investigation of June 13, 2018 Incident at Rock Island Dam, Gate No. 17

---

EXECUTIVE SUMMARY

The Chelan Public Utility District (“District”) retained Lane Powell on or about June 18, 2018 to conduct an independent investigation into the cause of a June 13, 2018 fatality at the Rock Island Dam, located approximately 12 miles downstream from Wenatchee, Washington. The incident took the life of Eddie Bromiley, a Central Maintenance Technician, who was gathering spillway gate load data during a scheduled gate lift test at spillway Gate 17. The District also tasked Lane Powell with identifying actions related to District engineering practices and/or procedures the District should implement and/or consider in an effort to prevent a similar incident.

Although a number of individuals we interviewed used the word “challenging” to describe the work environment at Rock Island Dam due to its age and the number of retrofits/improvements it has undergone since its construction in 1933, our initial fact-finding suggested that the June 13 incident did not result from an unsafe act or violation of District policy or procedure, from known hazardous working conditions at Gate 17, or from design, maintenance or operational deficiencies of which the District (or its personnel) had prior notice. The clear and overwhelming consensus of the individuals we interviewed was that the District has worked diligently to implement and enforce an appropriate culture of safety, free from fear of retaliation, governing daily operations at Rock Island.

As we were in the process of preparing our Memorandum summarizing our investigation, however, we learned for the first time, on December 3, 2018, that a District employee had come forward immediately following the June 13 incident with information that a concern was raised -- in or around the mid-1990s -- regarding the possibility that a swing rail could inadvertently lift vertically, become dislodged from the hinge assemblies securing it in place, and fall to the spillway deck. Immediate further investigation determined that the District

employee's account of a prior concern with swing rail safety was credible and that it appears no contemporaneous written documentation of any such concern was recorded, no service request submitted by the employee (or anyone else aware of the concern), nor written operational procedure adopted to address the concern on a going-forward basis. Instead, information regarding the potential safety concern was disseminated only verbally among relevant Rock Island personnel at that time. Regrettably, no one involved in any facet of the June 13 test lift of Gate 17, nor anyone else we interviewed as part of our investigation prior to December 3, reported to us ever having been made aware, directly or indirectly, of such a safety concern or ever having recognized or reasonably anticipated the possibility of risk posed by the specific combination of design and operational variables at play during the test lift of Gate 17 on the day of the incident.

We were not ultimately able to pinpoint conclusively the precise mechanical cause of the swing rail lifting, becoming detached and falling on June 13, due to the multiple forces (natural and man-made) and moving parts involved when using a gantry crane to lift a spillway gate. There is no video recording capturing the gate lift test operation at Gate 17 and none of the eyewitnesses was focused on the precise area of Gate 17 that appears to have triggered the incident. Nevertheless, as is discussed in greater detail below, our investigation and accompanying technical analysis, performed by an engineering firm with extensive experience in dam design and operation, concluded that the most probable explanation for the swing rail becoming dislodged was a slight rotation of Gantry Crane 3's north hoist block in its downstream track as the block began to lift after engaging Gate 17's north hook, which, in turn, caused the hoist block's leaders to catch what is believed to have been the horizontally misaligned bottom edge of the north "swing rail," lifting the rail until it became dislodged from its upper and lower hinge assemblies, fell and mortally wounded Technician Bromiley.

In addition to the above-referenced engineering consultant's analysis of Gate 17 and the particular operation in which it was engaged on June 13, we also, at the District's request, retained a consulting firm specializing in Human Performance Improvement to evaluate whether the District and/or Rock Island Dam's internal practices and procedures contributed in any way to the June 13, 2018 incident. That consultant identified the root cause of the June 13 incident as the District's failure to promptly and formally document and, as necessary, address through training and/or operational procedures the above-referenced swing rail-related safety concerns when they were first raised in the mid-1990s.

At our direction, both of our consultants separately assessed whether relevant District policies, practices and/or procedures can or should be modified prospectively in a manner that could enhance the operational safety of spillway bays with swing rails at Rock Island. A final and all-inclusive Table of each of our consultants' affirmative recommendations and, separately, potential modifications for the District to consider to its current engineering practices and operating procedures appears on pages 23-28 of this Memorandum. These recommendations include, among others: (1) adopting and applying relevant U.S. Army Corps of Engineers inspection and design guidance to Rock Island's spillway bays and Gantry Crane hoist blocks, (2) adopting additional procedures for dam operations using gantry cranes in an effort to

improve risk awareness and behavior mitigation associated with such operations, and (3) conducting an independent survey to ensure that potential safety concerns are promptly and formally documented and, where necessary in response, appropriate training and operational procedures are adopted and institutionalized. Potential modifications for consideration by the District include: modifying Gantry Crane 3 to allow it to better tolerate misalignment between fixed and swing rails while engaged in lifting operations, complete elimination of swing rails on the spillway, and specific changes to the current job planning processes and procedures.

## I. INVESTIGATION PROCESS

On three separate occasions (June 27-28, July 2-3, August 14-15), Lane Powell attorneys and our consulting engineer, James Costello, of Tetra Tech, Inc., traveled to Rock Island Dam to conduct the bulk of the fact-finding component of our investigation. Following a detailed briefing regarding our previous site visits and interviews, Fred Lake, our Human Performance Improvement (“HPI”) consultant from WD Associates, Inc., accompanied us on our third and final investigative visit to the Dam.<sup>1</sup>

On our first site visit, we toured Rock Island Dam and the scene of the June 13 incident. We also inspected spillway bay 17, as well as the swing rail that struck and killed Maintenance Technician Bromiley, which was removed from the spillway immediately following the incident and is stored in its original condition in a nearby maintenance yard. We also commenced witness interviews, which over the course of our three site visits included the following 25 District employees, several of whom have more than 25 years’ experience working in, on and/or around Rock Island:

- [REDACTED], Plant Mechanical Engineer (Witness)
- [REDACTED], Director of Safety, Labor, and Organizational Development
- [REDACTED], Journeyman Hydro Mechanic (Witness)
- [REDACTED], Mechanic Apprentice (Witness)
- [REDACTED], Plant Mechanical Foreman (Witness)
- [REDACTED], Principal Civil Engineer
- [REDACTED], Senior Mechanical Engineer
- [REDACTED], Foreman Hydro Mechanic (Witness)
- [REDACTED], Foreman Hydro Mechanic
- [REDACTED], Journeyman Mechanic
- [REDACTED], Hydro Mechanic Apprentice
- [REDACTED], Foreman Maintenance Mechanic
- [REDACTED], Hydro Mechanic
- [REDACTED], Plant Hydro Mechanic
- [REDACTED], Director of Central Maintenance
- [REDACTED], Central Maintenance Mechanical Superintendent

---

<sup>1</sup> Costello and Lake’s Curriculum Vitae are attached as **Attachment A**.

- [REDACTED], Organizational and Employee Development Manager
- [REDACTED], Director of Hydro Operations
- [REDACTED], Safety and Health Coordinator
- [REDACTED], Director of Engineering and Project Management
- [REDACTED], Distribution Operations Manager
- [REDACTED], Managing Director Human Resources and Safety
- [REDACTED], Rocky Reach-Lake Chelan Operation Superintendent
- [REDACTED], Journeyman Hydro Mechanic
- [REDACTED], Central Maintenance Technician

We were unable to interview two of the seven eyewitnesses to the incident, [REDACTED] and [REDACTED]. [REDACTED] and [REDACTED] are employees of Eureka Engineering Enterprises, a District engineering contractor, and were present on the spillway consulting with Technician Bromiley relevant to the Gate 17 test lift at the time of the incident. Eureka's attorneys imposed conditions upon our ability to interview [REDACTED] and [REDACTED], which we believed to be ill-advised and to which we recommended the District not agree; hence, they were not interviewed. Nevertheless, where appropriate, we have incorporated into this Memorandum information [REDACTED] and [REDACTED] provided in written statements provided immediately after the incident.

Each of the 25 individuals we interviewed was cooperative and we assured each that their candid and truthful statements regarding their observations on June 13, 2018, as well as their opinions concerning workplace safety in general, were protected by the District's non-retaliation policy.<sup>2</sup> In total, the interviews took approximately 60 hours to conduct.<sup>3</sup>

In addition to our interviews, we requested, received and reviewed the following categories of information and documents:

- Relevant historical materials (including engineering drawings, reports and emails) regarding Gate 17 operations
- Stone & Webster 1991 (August) Spillway Gate Modifications Preliminary Design Report
- Written statements provided by witnesses immediately following the incident
- Photos of Gate 17 and its vicinity taken immediately/shortly after the June 13 incident

---

<sup>2</sup> We alone identified the District employees we believed should be interviewed, and the District provided access to each. Nine of the interviewees are IBEW 77 union members and had union representation at their interviews. We found it necessary to conduct one or more brief follow-up interviews with several individuals to ask additional questions based on a review of our interview notes, information provided by other witnesses and/or information we developed that required explanation or clarification. In all instances, the District and relevant employees accommodated our requests for follow-up (and sometimes multiple follow-up) interviews.

<sup>3</sup> More than one interviewee expressed appreciation to us for our efforts and commended the District for its willingness to commission an independent investigation.

- Photos of Gate 17 and its vicinity taken following and to document the aftermath of a March 2017 “jam” of Gate 17
- September 20, 2017 Event Report to National Hydropower Association reporting the March 2017 gate operator failure at Gate 17
- Information and data collected during our Gate 17 site visits, as well as our own photos
- Gate 17 Maintenance and Operational Records, including Federal Energy Regulatory Commission (“FERC”) test records
- Planning emails related to June 13, 2018 gate load testing
- Fabrication drawings for the swing rail concept dated 1993
- “Near-Miss” Safety Reports
- Safety Concern Reports Submitted by District Personnel via Web Site/Hotline
- Tetra Tech’s Engineering Report and Analysis (**Attachment B**)
- WD Associates’ Root Cause Analysis Report (**Attachment C**)

In our judgment, all of the individuals we interviewed were candid and forthcoming in response to our questions. This facilitated a thorough and effective independent inquiry into the June 13 incident.

Based upon the consistent and unanimous responses of our original interview subjects, our initial impression was that Technician Bromiley’s death was not attributable to an unsafe act or violation of District policy or procedure, to known hazardous working conditions at Gate 17, or to design, maintenance or operational deficiencies of which the District (or its personnel) had prior notice. Not a single District employee we interviewed, who was assigned to the Dam and worked daily in and around the spillway gates at the time of the incident, including District employees with decades of service at Rock Island, reported ever having considered the possibility that this particular swing rail – or any other swing rail on the spillway – posed a risk of becoming dislodged from the gate in the unexpected manner that occurred with tragic consequences on June 13. *However*, as is discussed in greater detail *infra*, we subsequently learned from the District that an employee we had not originally interviewed, who was no longer assigned to Rock Island Dam, had raised a concern regarding possible detachment of a swing rail from its hinge assemblies, in much the same manner it did on June 13, shortly after the first two swing rails were installed at Rock Island in the mid-1990s. We immediately conducted additional fact-finding upon learning this new information and have incorporated that information in this Memorandum.

## II. BACKGROUND

### A. *Rock Island Dam.*

Rock Island Dam, is a hydroelectric dam operated by the District. The Dam is approximately 12 miles downstream from Wenatchee, and is the oldest dam on the Columbia River – built between 1929 and 1933. The Dam generates thousands of gigawatt-hours of electricity per year, which the District sells to various customers. The District also operates the Rocky Reach and Lake Chelan hydroelectric dams. The revenue generated from these dams allows the District to provide the community recreational facilities and other local services.

Over its almost 90 years in operation, Rock Island Dam has been the subject of numerous engineering studies and has undergone many upgrades and retrofits, one of which, as discussed below, is particularly relevant to the June 13 accident. It is our understanding that, prior to the June 13 incident, the District had commenced a feasibility study to examine overhauling and modernizing the Rock Island spillway.

Rock Island Dam has two powerhouses and 31 spillway “bays”, which vary in depth due to the topography of the Columbia River bed. *See* Diagram 1. There are 13 deep bays and 18 shallow bays. *Id.* The spillway has a total length of 1,424 feet and is divided by a center fish ladder. There are 14 spillway bays on the east side of the Dam and 17 on the west side. *Id.* Each bay has an upstream and a downstream “slot” with the bay’s gate positioned in the downstream slot. Gates, which can be comprised of two or three pinned-together segments depending upon the depth of the particular spillway bay, can be lifted to various heights to allow for water passage, as well as juvenile fish migration. Gate 17 has two segments – one 11 feet and one 22 feet in height.

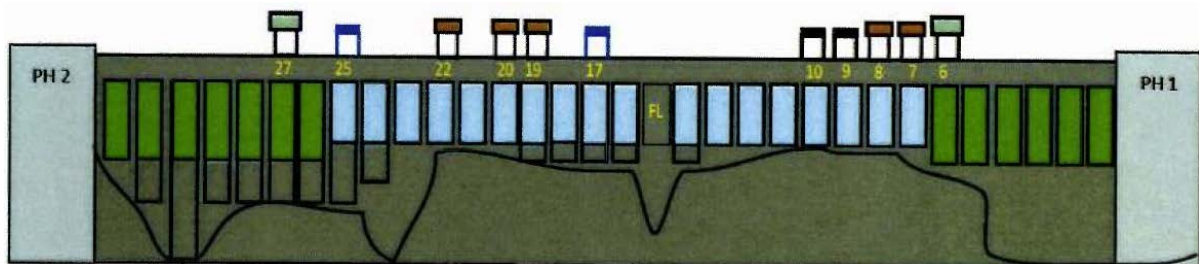

Diagram No. 1 - Rock Island Dam has two powerhouses (PH1 and PH2) and 31 spillway bays -- 13 (green) are deep bays, and 18 (blue) are shallow bays. The numbered gates, as discussed *infra*, are fixed-hoist bays.

Spillway gates are lifted by one of two types of hoists: gantry cranes and automatic fixed hoists. *See* Photo 1. When engaged in lift operations, both types of hoists are positioned over a spillway bay’s downstream slot in which the gate is situated. Rock Island Dam has three gantry cranes, only two of which are used to lift spillway gates (Cranes 2 and 3), that are maneuvered along the spillway on tracks to service and/or lift those gates not outfitted with a working fixed hoist. *See* Diagram 2. The gantry cranes, which lift gates by hooks attached to the top of both ends of the gate, can be operated as a fixed hoist from one of the Dam’s Control Rooms or

manually from the spillway using a handheld device. As is depicted in Diagram 1, eleven of Rock Island's 31 spillway bays are outfitted with the other type of hoist, a fixed hoist, which lifts gates from the bottom of the lower-most gate segment. Fixed hoists are permanently affixed to the top of the spillway bays, and are operated remotely by operators in the Control Room or by the computerized SCADA system. Gate 17 was outfitted with a fixed hoist, although, as discussed immediately below, the hoist failed and was removed prior to June 13, necessitating use of a gantry crane to lift Gate 17 on June 13.

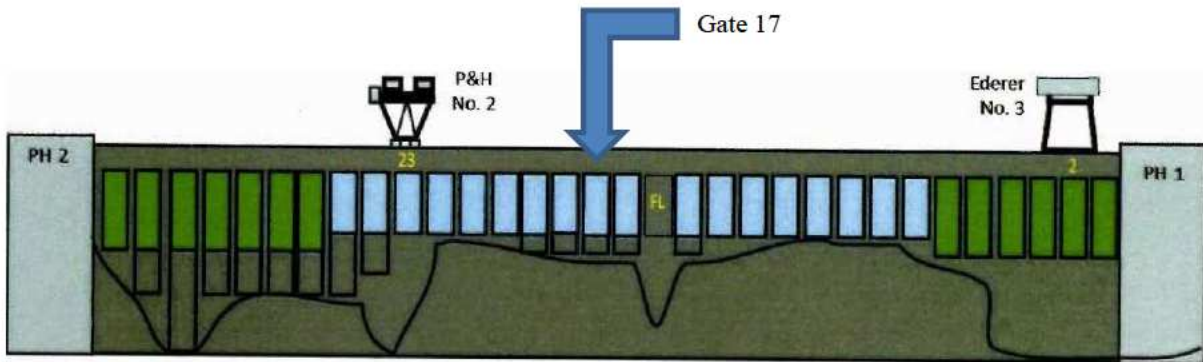

Diagram No. 2 - Rock Island Dam's two gantry cranes used in gate lifting operations are typically situated over Gate 23 and Gate 2. Gantry Crane 3 was used to lift Gate 17 on June 13, 2018.



Photo No. 1 - View of spillway bays along spillway deck. The spillway bay in foreground is outfitted with a fixed hoist while a gantry crane is positioned over bay/gate in background.

*B. Gate 17's Fixed Hoist Fails in March 2017; During Repairs, "Swing Rails" are Installed.*

On March 29, 2017, Gate 17 was partially lifted and being held in place by its fixed hoist. At approximately 11:38 pm, one of the cables on the fixed hoist snapped when one of the gearboxes in the fixed hoist failed (similar to a failure of Gate 25's auto-operator in 1986). The gearbox failure caused the load of Gate 17 to be supported by only the other gearbox and accompanying cable. Unable to withstand the weight of the entire gate, the remaining cable snapped in the early morning of March 30 and the gate fell and jammed in its slot.

As described in emails authored by Rock Island's Plant Mechanical Engineer, [REDACTED], and as confirmed by interviews with the crew responsible for the repairs, Gate 17 and, in particular, the north downstream rail, sustained significant damage as a result of the March 2017 fixed hoist failure and jamming of the gate. [REDACTED] stated that he carefully and thoroughly inspected the totality of both spillway bay 17 and Gate 17 both the morning following the fixed hoist failure as well as during the ensuing weeks to assess any damage and to identify needed repairs.<sup>4</sup> He also documented the condition of the bay and Gate 17 in dozens of photographs, which we examined and discussed with him. In addition to a series of email exchanges addressing the fixed hoist failure and related damage and repairs, the District summarized its internal investigation of the hoist failure in a written event report to the National Hydropower Association. It does not appear that the internal investigation included a safety evaluation of the hoist failure and subsequent gate jam.

In order to complete inspection and repair of Gate 17 and the surrounding area, the District first needed to remove the gate from its slot. However, to do so, the gate's "rail," to the north and south of the downstream side of the gate slot, which guide gates as they travel vertically while being raised and lowered, needed to be converted to a "swing rails." Although neither we nor the District was able to locate original design drawings for the swing rail concept, interviews with and research conducted by several senior, long-serving District employees point to the concept originating as part of a spillway rehabilitation project undertaken between 1992 and 1996, which, among other things, included installation of new 280-ton gate hoist assemblies at spillway bays 6 and 27. It remains unclear whether the swing rail design was developed internally by the District (with or without vetting by an outside firm) or was outsourced to an outside vendor or engineering consultant.<sup>5</sup>

---

<sup>4</sup> [REDACTED] advised us that bay 17 was "de-watered" to facilitate a top-to-bottom visual inspection of the bay.

<sup>5</sup> Although no design drawings could be located, we did locate fabrication drawings dated November 1993 and prepared by a steel fabrication firm, Coeur D'Alenes Co., located in Spokane, WA, for a customer identified as Cobra Corporation of Spokane, which served as the contractor for the spillway rehabilitation project. Interviews of District personnel point to the swing rail concept likely being designed and validated outside the District, given the relatively few engineers employed by the District in the early 1990s, but we cannot conclusively conclude that that was the case.

The conversion of fixed hoist spillway bays to the swing rail design was iterative over many years with the first bays, 6 and 27, reportedly converted in or around 1994 and the last of the 11 fixed hoist bays, bay 25, converted on November 28, 2017.<sup>6</sup> Our understanding is that conversion of the nine fixed hoist bays not converted in the 1994 time frame took place two decades later, between 2011 and 2017, driven primarily by emergency spill capability and planning. Conversions were typically planned in conjunction with ongoing maintenance or repairs or when some other logical opportunity existed. In the case of Gate 17, the repairs required following the March 29 gearbox failure and resulting gate jam presented such an opportunity and the swing rail conversion was completed on July 13, 2017.<sup>7</sup>

The maintenance crew that performed the swing rail conversion on bay 17 advised us that they closely adhered to drawings they had been provided. As on other gates with swing rails, the conversion required that both of bay 17's downstream rails – on the north and south sides of the gate slot – be split horizontally, and hinges welded to the rails approximately 4 feet and 12 feet above the split in the rails, as well as to an adjacent beam, to allow the rails to swing open like a door. *See* Photo 2. The rail above the horizontal cut is the “swing” rail portion of the rail and the rail below the horizontal cut is the “fixed” portion of the rail. *See* Photo 3. When both north and south swing rails are in the “open” position, the gate can be removed from its slot. For safety, and in addition to the “hinge pin,” the hinge has a place for a removable pin that, when manually inserted in place, allows the rails to be locked in the closed position. *See* Photo 4. This “locking pin” is in close proximity to the hinge pin, but is typically only used on the lower of the two hinges.<sup>8</sup>

---

<sup>6</sup> In addition to employee interviews, the installation date estimate for the first swing rails on the spillway is based upon the date of the fabrication drawings as well as other records related to the mid-1990s rehabilitation project, including technical specifications for the installation of new hoists at bays 6 and 27.

<sup>7</sup> Besides the dates provided above for bays 6, 17, 25 and 27, District records reflect the following completion dates for swing rail installations: bay 20 on October 4, 2011; bay 8 and bay 22 on October 3, 2014; bay 10 on September 19, 2016; bay 9 and bay 7 on July 12, 2016; and bay 19 on November 7, 2017.

<sup>8</sup> In contrast to the fixed and more substantial hinge pin, the locking pin has a loop hook on the top so that it can be easily removed when the crew needs to open the rail. *See* Photo 4. If the locking pin is not in place during a gate lift, the swing rail could unintentionally swing open. To our knowledge, no one at Rock Island Dam has ever been injured by an unlocked swing rail.

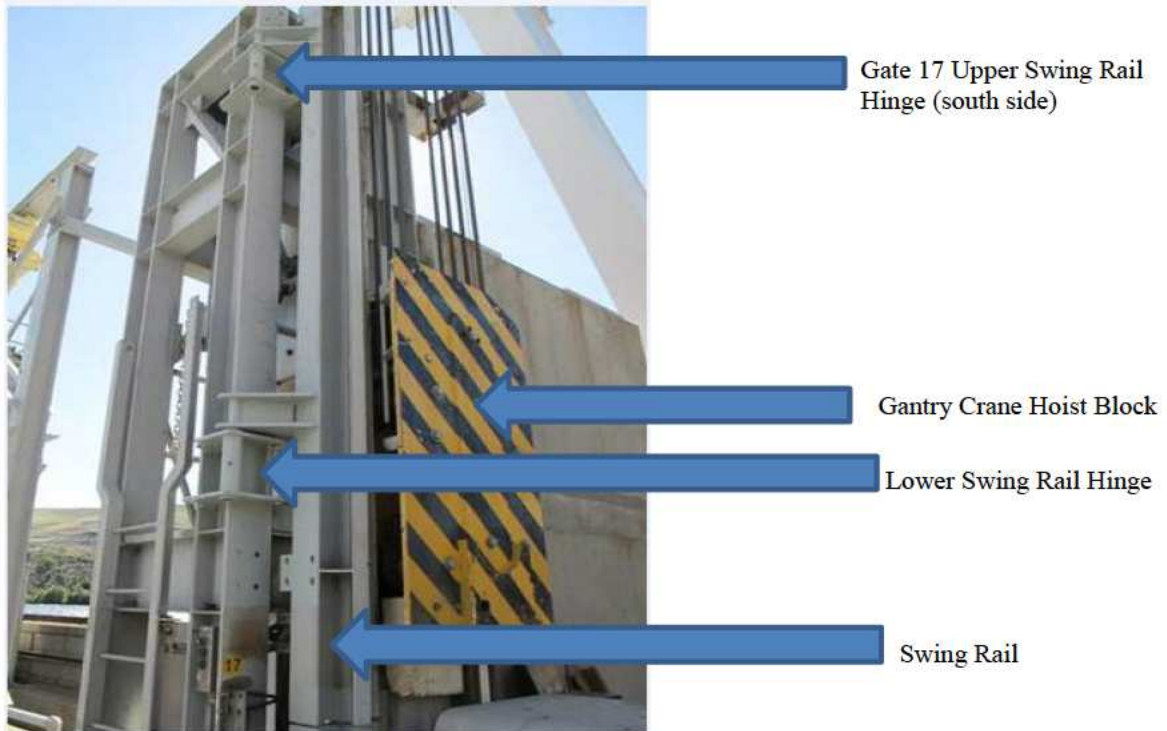

Photo No. 2

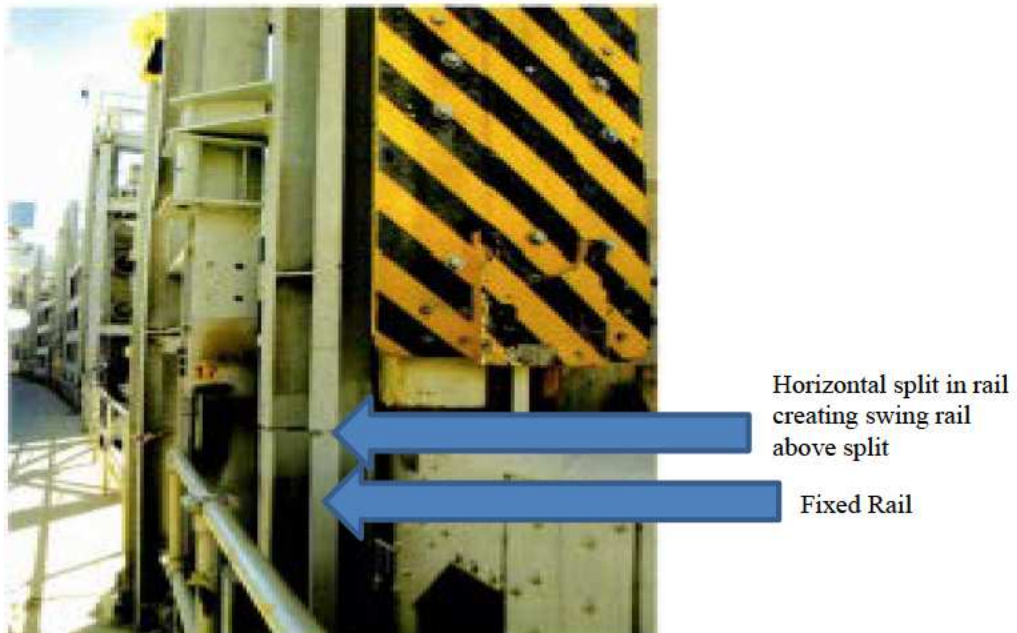

Photo No. 3



Photo No. 4 - Gate 17's north swing rail lower hinge assembly with hinge pin (left) and locking pin (right). The swing rail was removed from the spillway after the incident and relocated to a maintenance yard adjacent to the Dam.

After Gate 17's conversion to a swing rail, the gate was removed from its slot using a gantry crane (since the fixed hoist was inoperable) in order to allow Dam personnel to access, inspect and repair the damage caused by the gate suddenly jamming. Repairs were completed on or about August 9, 2017 and the gate re-installed. The gate was lifted to full height (likely by Crane 2) to assess whether the repairs were effective and the gate fully operational.<sup>9</sup> This lift was conducted without incident. In the meantime, the District turned its attention to replacing the fixed hoist on Gate 17. Given that the hoist had failed under the load of the gate, the District undertook to analyze if an upgrade to the existing equipment on both Gate 17 and Gate 25, which had failed previously, was necessary to prevent yet another failure. To do so, the District determined that it should, as soon as practicable, gather data regarding the loads generated by Gates 17 and 25 during lifts, so replacement hoists would be capable of accommodating their respective loads.

*C. Gate 17 Lifted Approximately 8 Feet for May 2018 Annual FERC Testing.*

On May 11, 2018, just over a month prior to the June 13 incident, the District performed annual, FERC-mandated gate testing at Rock Island Dam. FERC tests are performed by District employees and the results are reported to FERC. Annual testing need only be

---

<sup>9</sup> We were unable to locate documentation that Crane 2 was used to test Gate 17 before it was returned to service, but District personnel opined that it was highly likely, since Crane 2 is typically located on the same side of the spillway as Gate 17, *see* Diagram 2, and the District tries to avoid moving cranes across the center fish ladder whenever possible.

completed within a certain timeframe, so is not scheduled for any particular day. Every year, the District is required to lift all spillway gates at least two feet, and at least several of the gates to full height. In 2018, Gates 22 – 27 were scheduled to be raised to full height. The May 11 FERC test was the first lift of Gate 17 since it had been repaired, reinstalled, and successfully test-lifted to full height following the gate jam in March 2017.

Our investigation, review of relevant documents, and interview of the senior crewmembers involved in the May 11, 2018 FERC exercise, reveals that the lift of Gate 17 was entirely uneventful. Using Gantry Crane 2, the crew lifted Gate 17 somewhere between five and eight feet off the bottom of the gate slot. The crane operator stated to us that the crew experienced no complications or irregularities and that neither he nor his crew observed any lifting or other unanticipated movement of Gate 17's swing rails during the FERC test lift.

*D. The June 13, 2018 Load-Testing Operation.*

In June 2018, the District commenced gathering data on the hydrodynamic lift loads of various gates. As noted above, Gates 17 and 25 were two of the gates for which accurate load data were needed before new fixed hoists could be ordered and installed.

As is reflected in email traffic beginning on June 7 between those responsible for planning the load testing, the testing was scheduled for Wednesday, June 13, 2018. The weekend before, Technician Bromiley and several other District employees prepared Crane 3 to be used for the operation.<sup>10</sup> Specifically, they calibrated the crane's load cells to be sure that the readings would be accurate. Because Bromiley was a member of the crew that calibrated Crane 3, he was designated as the technician to record the data measurements on June 13. Two contract engineers from Eureka Engineering Enterprises, [REDACTED] and [REDACTED], were to be present to assist with data gathering. The crew responsible for the gate-lift aspect of the operation included [REDACTED], Plant Mechanical Foreman (hired May 1984); [REDACTED], Journeyman Hydro Mechanic (hired December 2009); and [REDACTED], Mechanic Apprentice (hired August 2017).

As is standard procedure, the gate-lift and data-gathering crews met on the morning of June 13 to discuss the plan for the day's operation and generate a Pre-Task Plan. The meeting included the gate lift crew, data gathering personnel, and on-duty operations personnel.<sup>11</sup> The crew and test personnel proceeded to Gate 3 to start gathering load data, but Technician Bromiley encountered an issue with his computer, so the operation was delayed several hours until the technical issue was resolved. All involved re-convened at Gate 3 at approximately 1:30 pm, at which time they were able to begin load testing.

---

<sup>10</sup> Despite the fact that it is typically located on the opposite side of the fish ladder situated in the middle of the spillway, Gantry Crane 3 was used instead of Gantry Crane 2 (used in the May FERC lift) because it had the necessary equipment to measure and record the relevant load data.

<sup>11</sup> Recollections differ over whether [REDACTED] was present for the Pre-Task planning meeting or whether he joined the crew immediately afterwards and was briefed on the day's operation by [REDACTED].

Each of the several gates for which load data was needed was to be lifted to full height three times with Crane 3. The team accomplished lifts on three other gates (Gates 3, 11 and 13) before moving to Gate 17. Those lifts proceeded without incident. Foreman [REDACTED] was the crane operator, and maneuvered Crane 3 across the fish ladder and over to Gate 17. Technician Bromiley walked alongside the crane on the spillway deck to avoid having to disconnect his laptop computer from the crane's power outlet and then reconnect it once positioned at Gate 17.

Upon arriving at Gate 17 at approximately 2:30 pm, Technician Bromiley placed his laptop on a folding table that he moved from spillway bay to spillway bay. The table was set up on the downstream wall of the spillway, directly across from Gate 17. As Foreman [REDACTED] prepared to engage Gate 17 with the gantry crane, he stood in the middle of the spillway deck, between Gate 17's north and south rails, so he could see both of the crane's hoist blocks, which he lowered and raised using a handheld remote. Journeyman Hydro Mechanic [REDACTED], who had not previously been involved in an operation involving a swing rail, was assigned to the south side rail of the gate (to [REDACTED]'s left facing upstream), and Mechanic Apprentice [REDACTED], who had not previously been assigned work on the spillway deck, was assigned to the north side rail of the gate (to [REDACTED]'s right facing upstream). See Attachment 1 (Diagram of Accident Scene) to **Attachment C**, WD Associates' Root Cause Analysis Report. [REDACTED] and [REDACTED] were responsible for ensuring that the crane's blocks properly latched onto the hooks on the top of each end of the gate as it sat lowered in its slot. It is essential that the crane properly latches onto the gate's hooks located at the top of the north and south ends of the closed gate; otherwise, a gate could be engaged on only one hook, thereby overloading one side of the crane's cables as the gate is raised.

After Crane 3's hoist blocks engaged Gate 17's hooks, [REDACTED] began to lift the gate. Moments later, [REDACTED] called a safety stop to the lift, as he noticed that the south side swing rail's locking pin was not in place securing the swing rail in the closed position. Instead, the locking pin had been left on top of the lower rail hinge. [REDACTED] immediately halted the lift while [REDACTED] climbed up to the hinge and replaced the locking pin. [REDACTED] walked over to the south rail, visually confirmed that the locking pin appeared to be securely in place, and also pulled on the south swing rail to make certain it would not move. He then returned to the north rail as [REDACTED] descended to the spillway deck and the crew resumed the lift.

As the crew proceeded to lift Gate 17, the Control Room, which jointly monitors gate lifts, called on the radio and asked that the lift crew confirm that both the 22 foot and 11 foot sections of Gate 17 were pinned together and would both be lifted by the crane. [REDACTED], [REDACTED], and [REDACTED] were confident that the two gates were pinned together, but turned their attention downward nonetheless in the direction of the gate slot to confirm.

With their focus directed down into the gate slot as the gate lift proceeded, [REDACTED], [REDACTED], and [REDACTED] reported hearing a very loud noise and a scream. With no warning whatsoever, both the upper and lower north rail hinge pins (together with the lower locking pin), which rest

in well-lubricated cylinders to facilitate the smooth operation of the hinge, lifted entirely out of their housing, causing the rail to come loose from the hinge assembly. Without any audible warning, likely due to a combination of how well-lubricated the hinge pin cylinder is and the significant noise created by the flow of water through and around the spillway, the north rail, weighing approximately 1,900 pounds, fell vertically to the spillway deck on its end, creating a divot in the concrete. After striking the spillway deck, the rail tipped on its edge and fell downstream. Contractor [REDACTED]' written statement reflects that, despite the noise from water rushing through the surrounding gates, the sound of the rail's edge hitting the deck startled her, and she narrowly missed being struck by the rail as she avoided its path. [REDACTED] recalls seeing the rail begin to fall and calling out, "Look out!," but does not recall at precisely what point and doubts that Technician Bromiley would have heard his warning in time. Tragically, the rail struck Bromiley, who was wearing a safety helmet, in the back of the skull as he was bent over his computer monitoring the load data with his back/side to the gate.

[REDACTED] immediately rushed to his colleague's side and lifted the rail off Bromiley, who was lying on the ground partially under it. Rock Island Dam EMTs were called, as was an ambulance. Despite lifesaving measures, Bromiley was declared dead at the scene. The time was approximately 2:45 pm. Understandably, those who witnessed the accident were distraught. Many were in a state of shock, as evidenced by [REDACTED]'s physical ability to lift the 1,900-pound rail off Bromiley, which [REDACTED] does not recall to this day, but which others recounted to us. Each witness, in addition to all responding EMTs, provided written statements before leaving the scene that evening.

#### *E. Safety Measures Implemented Following June 13 Accident.*

Immediately following the June 13 incident, and while separate investigations by our team and the State Department of Labor & Industries commenced into the cause of the swing rail detachment, personnel at Rock Island Dam considered and implemented several interim measures to address and prevent a recurrence of the incident:

- First, and most notably, Gate 17 was red-tagged and remains out-of-service with its north swing rail still removed. Gate 25, which experienced a fixed hoist failure in 1986 similar to the failure of Gate 17's hoist in March 2017 and requires a gantry crane to lift it, was also taken out of service, but was fully inspected and returned to service on August 30, 2018, following removal of its swing rails. Gates 17 and 25 are currently the only spill bays on the Dam with both swing rails and out-of-service fixed hoists.
- Second, for gate lifts requiring the use of a gantry crane, only essential personnel (the crane operator and other Dam personnel assigned to monitor the crane latching onto the gate hooks) are permitted on the spillway deck during the gate lift. Traffic seeking to cross the spillway (whether on foot or vehicular) is halted and required to wait until the lift operation is complete before entering the spillway deck.

- Third, signs have been placed at each gate with a fixed hoist stating, “WARNING! Open swing rail when using gantry crane to lift, remove or install gate section.”
- Fourth, on each of the gates that have swing rails, the District replaced the locking pin with a Grade 8 bolt secured at the base of the hinge by a Grade 8 nut to prevent the swing rail from lifting. We were informed by District personnel that subsequent analysis by Black and Veatch, an engineering firm consulted by the District, advised that while the maximum lifting capacity of the gantry crane could likely distort the hinge assembly even with the bolt in place, the bolt and the temporary resistance it should generate would provide a crane crew with warning of a potential problem with the swing rail and a brief window of opportunity to avoid possible injury.

In addition to these measures, the District is in the process of moving forward with one additional safety measure for spillway bays with swing rails. The District plans to weld a 1” wide steel plate to the stanchion onto which the hinge pin assembly is mounted that will sit approximately 1/8” above the centerline top of the hinge. As contemplated, the plate will be positioned in such a way that it should impede upward movement of the hinge assembly in the event that, as on June 13, the swing rail were somehow engaged and lifted. We were informed by District personnel that Black and Veatch had again concluded that the resistance generated by the steel plate could not stall a gantry crane involved in a gate lift, but that the temporary interference of the plate with any vertical movement of the swing rail should be sufficient to alert the lift crew to a potential problem before the plate is overtaken by the force of the crane.

With the assistance of Black and Veatch, the District identified yet another possible prospective “fix” -- installation of a rail “splice plate.” Such a plate would be used to bolt the swing and fixed rails together ensuring their alignment while the rail is closed and requiring that the bolts be removed before the swing rail can be opened. While this appeared to be a promising safety measure, since its efficacy is not impacted by the lifting capacity of Cranes 2 and 3, the District has put this fix on hold because of unanticipated difficulties with its implementation.

Separate and apart from these implemented and contemplated measures, it is our understanding that the spillway modernization program the District is currently considering will, if authorized, undertake a re-evaluation of the continued use of swing rails on the spillway as a priority action item.

### III. CAUSATION ANALYSIS

#### A. *What Caused the Swing Rail to Unexpectedly Lift and Become Dislodged?*

As is described in the Executive Summary and is explained and depicted in detail in our engineering consultant’s report, attached as **Attachment B** to this Memorandum, Tetra Tech concluded that the most probable explanation for the June 13 incident was a slight rotation of Crane 3’s north hoist block in its downstream track as it began to lift after engaging Gate 17’s

north hook, which, in turn, caused the hoist block's leaders to catch what is believed to have been the horizontally misaligned bottom edge of the north swing rail, lifting the rail until it became dislodged from its upper and lower hinge assemblies, fell and mortally wounded Technician Bromiley.<sup>12</sup> This sequence of events is described, depicted with photos and diagrams, and explained in detail in the "Root Cause Analysis" at Section 4.3 of Tetra Tech's Report.

*B. Did District Behavioral, Programmatic and/or Organizational Practices Play a Role in the June 13 Incident?*

Our HPI consultant's Root Cause Analysis of the June 13 incident, attached as **Attachment C** to this Memorandum, identified the root cause as the District's failure to promptly and formally document and, as necessary, address through training and/or operational practices the swing rail-related safety concerns that were first raised in the mid-1990s. As a consequence and moving forward, the District failed to recognize the potential risk of utilizing gantry cranes to lift gates with fixed hoists in spillway bays modified with swing rails and, therefore, failed to recognize and seize the opportunity to mitigate the potential risk by: (1) controlling access of non-essential personnel to the lift zone, (2) assigning a crew member to maintain an overall perspective of the lift, and (3) adopting additional operating procedures for gantry crane lifts of spillway gates.

#### **IV. DISCUSSION AND RECOMMENDATIONS**

*A. The Mechanical Issues Experienced at Gate 17 on June 13, 2018, as Identified and Analyzed by Tetra Tech, Were Neither Anticipated by Rock Island Personnel at the Time of the Incident nor Apparent to the Crew Involved in the Load Testing Operation.*

As noted elsewhere in this Memorandum, none of the individuals we interviewed prior to December 3 had identified or expressed to us concerns regarding the safety of the swing rails installed on two of the Dam's eleven spill bays in the 1994 time frame and on the remainder of the bays between 2014 and November 2017, nor did anyone we initially interviewed relate concerns they had heard others express about the design, operation or safety of the swing rails deployed across the Dam. Similarly, no one we initially interviewed expressed concerns to us, or directed us to others with concerns, regarding the practice of using gantry cranes to lift gates equipped with fixed hoists. Indeed, Gate 17 was safely and without reported complications lifted to full height by Crane 2 in or about August 2017 after completion of repairs necessitated by the March 2017 fixed hoist cable failure and resulting jam of the gate in its slot. Moreover,

---

<sup>12</sup> Because Gate 17's north swing rail became detached and fell on June 13, there is no way to determine that it was, in fact, misaligned with the fixed portion of the rail at the time of the incident and, if so, to what degree. Measurements taken during our post-incident site visits by our engineering consultant at other spill bays with swing rails revealed horizontal misalignment of between 1/16 and 3/16 of an inch. Examples of such misalignment are depicted in Photos 5 and 6 of Tetra Tech's report, including some slight horizontal misalignment at Gate 17's south swing rail.

and importantly, Gate 17 was again lifted safely and without reported complications by Crane 2 as part of a FERC-mandated exercise on May 11, 2018, almost exactly one month prior to the June 13, 2018 incident. Although Crane 3 and not Crane 2 was used to lift Gate 17 on June 13, our investigation revealed no known material, operational or maintenance issues with Crane 3, nor other concerns about its use on the date of the incident, which was dictated by Crane 3's having the necessary equipment to measure and record the relevant load test data.<sup>13</sup> Prior to June 13, Crane 3 was used on at least two recent occasions to successfully, and without reported complications, lift other fixed hoist gates -- Gates 7 (in 2017) and 27 (in 2015).

In addition, based upon Tetra Tech's analysis and explanation of the likely mechanical cause of the June 13 incident, neither the north hoist block's slight rotation as it began to lift Gate 17 nor the block's leaders catching the bottom edge of Gate 17's north swing rail would have been obvious, or even visible, to the District crew engaged in lifting Gate 17. Both the hoist block's rotation on its track and the block's leaders catching the bottom edge of the swing rail would have taken place *inside* of the hoist block assembly and, therefore, would not have been observed by the crew. Not until the swing rail itself began to lift vertically would the crew have conceivably been in a position to notice a problem and the corresponding danger. As noted above, however, at the precise moment the swing rail began to lift, the crew's attention was focused downward into the gate slot in response to a call from the Control Room, asking the crew to verify that both of Gate 17's gate sections had been engaged and were being lifted.

It took only seconds for the swing rail to rise roughly 11 inches, the length of the upper and lower hinge pins that keep the swing rail connected to the adjacent stanchion to which the hinge is affixed, for the swing rail to become detached, and for the swing rail to fall towards and fatally strike Bromiley. By the time Apprentice ██████ noticed that the swing rail was falling and yelled "Look out!," it was too late, even assuming his warning would have been audible over the noise generated by the rush of water through the surrounding spillway gates.<sup>14</sup>

---

<sup>13</sup> When asked about maintenance issues with Crane 3's hoist block, Plant Mechanical Engineer ██████ identified the issue of the block's rollers occasionally "sticking" -- an issue to which Tetra Tech's report recommends paying attention in the future. Although the rollers are designed to be self-lubricating, ██████ advised maintenance technicians prior to June 13 to periodically apply lubricant to them. Tetra Tech considered whether the blocks' rollers occasionally sticking may have been a contributing cause of the June 13 incident, but ultimately, after analyzing the issue, declined to identify the rollers as a having played a material role.

<sup>14</sup> One interviewee, who responded to the spillway after the swing rail fell and hit Bromiley, expressed a concern that wind may have played a role in the incident. We gathered what publicly-available data we could regarding the wind that day. Wind readings in the Wenatchee area on the afternoon of June 13 were in the range of gusts up to or just over 20mph. We raised the concern about wind with the crew members involved in the lift of Gate 17 in follow-up interviews and with Plant Mechanical Engineer ██████, who witnessed the incident. None of them, either at the time of the incident or subsequently, felt that the wind at the time of the incident, which none of them recalled to be substantial, was a cause of the incident. Tetra Tech also considered the possibility that wind may have played a role in the incident, but included nothing about wind as a likely cause/contributing cause of the incident in its final report.

*B. New Information Surfaces Regarding Early Swing Rail Design Concerns.*

On December 3, 2018, we learned for the first time from the District that an employee who we had not previously interviewed, ██████████, had seen the publicly-posted letter that District General Manager Wright had sent to L&I disputing the Serious Violations and corresponding penalties that L&I had assessed following its investigation of the June 13 incident and that ██████████ had expressed the view that statements in Wright's letter to L&I were not accurate. Specifically, we were advised that ██████████ had stated that he had expressed concerns about the possibility of a swing rail lifting out of its hinge assembly and falling to the spillway deck sometime shortly after the first swing rail was installed at Rock Island in approximately 1994.

We immediately contacted ██████████ and interviewed him from Seattle via video teleconference the next day, December 4, 2018. ██████████, who is currently a Plant Superintendent at Rocky Reach Dam, but who served as a Journeyman Hydro Mechanic at Rock Island during the 1990s and beyond, informed us that shortly after the installation of the first swing rails at Rock Island's spillway bays 6 and 27 in approximately 1994, he both witnessed a swing rail and its hinge pin begin to lift vertically during what he recalls to have been a gate lift and reported his observation to his supervisors, including, as he recalls, to then-Plant Supervisor ██████████.<sup>15</sup> According to ██████████, discussion ensued among a number of Rock Island personnel regarding how to deal with the fact that if a piece of equipment or machinery were to become entangled with or to engage a swing rail, the swing rail could unexpectedly lift vertically and eventually come loose from the hinge assemblies connecting it to the spillway bay, since there is nothing to keep the hinge pin anchoring the swing rail to a nearby stanchion in place.

██████████ stated that he and his colleagues altered their practice for lifting gates at bays modified with swing rails so as to avoid the possibility of something inadvertently catching a swing rail and causing it to lift unexpectedly. Specifically, he explained that they would engage the hooks at the top of Gates 6 and 27, both deep bay gates with working fixed hoists, with gantry crane hoist blocks only if the gates were already raised by the fixed hoist to the point where the hooks mounted on the top of and at the end of the gates were *above* the bottom edge of the swing rail.<sup>16</sup> He noted that this practice was not memorialized at the time because the District did not then have in place a tool similar to the Maximo computer program that the District uses today for, among other things, management and scheduling of maintenance and related procedures. In addition, and similarly, it appears no contemporaneous written documentation

---

<sup>15</sup> ██████████ stated that as soon as he saw the swing rail begin to lift, as well as the portion of the hinge pin he recalls typically protruding slightly from beneath the hinge assembly begin to disappear, he and others halted the gate lift and immediately conferred about how to prevent something similar from happening in the future.

<sup>16</sup> Bay 17 was neither a deep bay nor was its fixed hoist operational on the date of the incident, so the practice described by ██████████ as having been adopted in the mid-1990s could not have been implemented in connection with the load test lift of Gate 17 on June 13.

of this potential issue was ever recorded and no service request to address the concern ever submitted by the individuals who noticed the issue.

████████ further explained that the practice adopted to avoid the possibility of a swing rail accidentally lifting was communicated verbally from employee to employee and handed down from more experienced Rock Island workers to their less experienced co-workers as new personnel joined the Rock Island spillway workforce. It appears that between the initial installation of swing rails at Rock Island in approximately 1994, continued installation of swing rails between 2011 and 2017, and the June 13 incident, employees with awareness of (1) the possibility that swing rails could unexpectedly lift out of the hinges securing them and/or (2) the practice adopted informally to avoid a safety issue either retired from or left the District, died, or, in the case of ██████████, were transferred from Rock Island, resulting in interruption of word-of-mouth dissemination of any swing rail concerns, as well as the related “work-around” practice.

Since initially raising the above-referenced concern with co-workers and managers in the 1994-1996 time frame, ██████████ has no recollection of discussing it with anyone again until the evening of the June 13 incident, after learning that it was a swing rail that became dislodged and struck Bromiley. He stated that he told ██████████, Director of Hydro Operations, that evening that he had had a concern many years prior that he had shared with co-workers that a swing rail could become dislodged and fall to the spillway deck in much the same manner as had just occurred. ██████████, who we had previously interviewed, said nothing to us about such a conversation and did not initially recall a conversation with ██████████ on June 13 until he was informed what ██████████ had told us during his December 4 interview. Upon reflection, ██████████ now has a vague recollection of ██████████ approaching him in a crowded room sometime shortly after the June 13 incident and sharing with him the fact that certain Rock Island “gate crews” had been aware of the risk that a swing rail could potentially detach from the adjoining stanchion and fall to the spillway deck. ██████████’s recollection is that ██████████ neither differentiated between knowledge of the swing rail concern possessed by current versus past gate crewmembers nor provided information regarding practices or procedures adopted in an effort to avoid the concern.

████████ further stated that although he was aware that we were conducting an independent investigation into the cause of the June 13 incident, he assumed that ██████████ had not thought his involvement in the investigation was necessary or we would have contacted him. Indeed, ██████████ did not raise his historical swing rail concern again from the time he mentioned it to ██████████ in the frenetic hours following the June 13 incident until he saw District General Manager Wright’s letter to L&I on December 3, 2018 and told ██████████ that it was factually inaccurate for the reasons he had previously shared with ██████████.

We find ██████████ and the information he shared to be credible. He has a clear recollection of a concern about a swing rail inadvertently lifting, coming loose and falling to the spillway deck and also of discussing his concern with co-workers and a Rock Island Plant Supervisor. Moreover, in addition to ██████████ at least one other District employee, ██████████, who worked

as an Apprentice at Rock Island between 1993 and 1997 or 1998, recalls conversations with more senior Rock Island personnel, including ██████████, to the effect that they needed to pay attention to the hinge pin on the newly installed swing rails because of the possibility the pin could lift out of the hinge assemblies, allowing the swing rail to fall to the deck.<sup>17</sup> ██████████ never observed a swing rail actually begin to lift vertically from its hinge assembly, as ██████████ states he did, but ██████████ reported having concerns that that could happen, based upon one or more instances when, while engaged in spillway operations, he observed a gantry crane hoist block come close to the hinge that houses the swing rail hinge pin. ██████████'s concern was that if something involved in a lifting operation (like a hoist block) caught on the hinge and lifted it, the hinge pin could lift out of the hinge and the swing rail could fall to the spillway deck.

In sum, there is credible evidence that concerns regarding the possibility of an unexpected vertical lifting and resulting fall of a swing rail were first raised shortly after swing rails were installed on two spillway bays in the mid-1990s. Rather than memorialize those concerns in writing or submit a service request to address the underlying issue, it appears, for reasons that remain unclear, that less formal means -- essentially word-of-mouth -- were adopted in an attempt to disseminate information both about the concern and a "work-around" practice to follow to minimize the chance that something might catch a swing rail, inadvertently lift it, and cause it to separate from the hinge assemblies holding it in place and fall to the spillway deck. Continued reliance upon informal communication of important operational information coupled with departures, retirements and/or reassignments of knowledgeable personnel likely accounts for why continued and on-going discussion of both the possibility of a swing rail inadvertently becoming dislodged and falling and the procedural work-around apparently ceased sometime well in advance of the June 13 incident.

*C. Given that Historical Concerns Regarding Swing Rail Safety Were Never Documented, More Rigorous Pre-Operation Planning and/or Adoption of Procedures Governing Operations Involving Gantry and Bridge Cranes Likely Would Not Have Identified the Risk that Gate 17's North Swing Rail Might Become Dislodged, but Such Measures Could Possibly Have Detected the Swing Rail's Lifting and/or Mitigated the Effects of its Fall.*

Our HPI consultant determined that the root cause of the June 13 incident, from a workplace policies and procedures perspective, was the fact that swing rail-related safety concerns first identified in the 1990's were not promptly and formally documented, nor was appropriate training and/or work practices adopted and institutionalized by the District to address the safety concerns. Instead, both the concerns and a "work-around" practice to mitigate the concerns

---

<sup>17</sup> In addition to ██████████ and ██████████, we re-interviewed ██████████, who also started work on Rock Island's spillway just after the swing rails were introduced. ██████████ has no recollection of any discussion by ██████████ or anyone else during that time frame regarding safety concerns related to the swing rails and no recollection of a practice adopted (formally or informally) to mitigate any such safety concern. Both ██████████ and ██████████ identified other co-workers, including former District employees, who they felt could corroborate the information they related to us, but, in consultation with the District, we determined that ██████████ and ██████████'s recollections were sufficient and that further corroboration was unnecessary.

were communicated informally by word-of-mouth by and between District employees assigned to Rock Island. Had the above-referenced concerns regarding swing rail safety been continuously disseminated by word-of-mouth (despite not being a best practice) or been timely documented and adequately addressed, as District policies and procedures implemented since the mid-1990s, but before the June 13 incident, currently require, those concerns could, and presumably would, have identified the possibility that a swing rail could lift out of and become detached from its hinge assembly, which would, in turn, have informed and enhanced pre-job planning for lifts of fixed hoist gates with gantry cranes, which, fortuitously, had been accomplished safely and without reported incident for over 20 years.

While the spillway personnel we interviewed uniformly expressed the belief that pre-job planning is adequate and while pre-job planning, as noted, occurred in connection with the collection of load test data at several gates, including Gate 17, on June 13, several interviewees with responsibility for safety, as well as our HPI consultant, believe that pre-job planning could and should be more rigorous and standardized. Specifically, our HPI consultant concluded that neither work planning nor the Pre-Task Plan for the collection of load test data: (1) established a “safe zone” for workers not directly involved in the operation, (2) provided for assignment of a “spotter” to maintain overall perspective of the gate lifts and to continuously monitor for hazards, and/or (3) established controls to restrict the movement of personnel/traffic along the spillway during lift operations. He also concluded that the District should consider developing and disseminating standards for Pre-Job Plans so that uniform expectations for such planning exists and the focus of such planning is clearly understood to be identification and mitigation of job risk.

In addition to more robust and substantive pre-job planning, our HPI consultant also identified the need for the District to adopt procedures for operations utilizing gantry and bridge cranes. As an initial matter, he opined that District policies and procedures for operations involving mobile cranes (cranes mounted on crawlers or rubber-tired carriers) give greater consideration to safety than policies and procedures addressing use of gantry cranes along the spillway. For example, our consultant observed that the District’s Spillway Gate Operations Manual does not contain requirements or a specified procedure for lifting a fixed hoist gate with a gantry crane – the operation giving rise to the June 13 incident. Similarly, the Gantry Crane Operations Manual contains no requirement for a dedicated “spotter” with responsibility for maintaining overall job perspective or restrictions on the location of personnel not directly involved in lift operations. In contrast, when utilizing mobile cranes, District policies and procedures require spotters and lift plans that designate “safe zones.”

With respect to assignment of a spotter, it is conceivable, but not certain, that if District gantry crane procedures had required a dedicated spotter, rather than allowing a crew utilizing a “working” Foreman responsible for crane operation and overall job oversight, a spotter could possibly have noticed Gate 17’s north swing rail rising and called a halt to the lift before the swing rail lifted entirely out of its hinge and became completely dislodged or provided an earlier audible warning than Apprentice ██████ shouted. Similarly, had gantry crane procedures restricted personnel not directly engaged in lift operations (Technician Bromiley

and the consultants from Eureka Engineering) from positioning themselves under the gantry crane during the lift and/or had more rigorous pre-job planning recognized and mitigated the potential risks posed by gantry cranes lifting fixed hoist gates, the falling swing rail may have fallen to the spillway harming no one. Putting to one side swing rail-related concerns, general recognition of the fact that gantry crane operations pose many of the same risks as mobile cranes and adoption of equally stringent safety and planning procedures for the former as the latter could very likely help to prevent a future loss of life on the spillway during what have, heretofore, been considered relatively routine, low risk gate lifts.

*D. Consultant Recommendations and Potential Modifications to District Engineering Practices and Operating Procedures for Future Consideration.*

As noted at the outset of this Memorandum, based on the findings of our investigation, including the information provided by [REDACTED], we directed our engineering and HPI consultants to make affirmative recommendations and also, if appropriate, to suggest modifications for the District to consider to its current engineering practices and procedures. A final and comprehensive Table of each of these recommendations and suggestions for consideration are re-produced below. These recommendations include, among others: (1) adopting and applying relevant U.S. Army Corps of Engineers inspection and design guidance to Rock Island's spillway bays and Gantry Crane hoist blocks, (2) adopting additional procedures for dam operations using gantry cranes in an effort to improve risk awareness and behavior mitigation associated with such operations, and (3) conducting an independent survey to ensure that potential safety concerns are promptly and formally documented and, where necessary in response, appropriate training and operational procedures are adopted and institutionalized. Potential modifications for consideration by the District include: modifying Gantry Crane 3 to allow it to better tolerate misalignment between fixed and swing rails while engaged in lifting operations, complete elimination of swing rails on the spillway, and specific changes to the current pre-job planning process.

**Final and All-Inclusive Table of Consultant Recommendations**

<b>Tetra Tech</b>	
	<b>Recommendations</b>
<b>TTR1</b>	<p>Inspect all spillway bays with swing rails. The current condition of the rails should be documented and evaluated as to whether their alignment is a concern. For reference and use during the inspection, it is recommended to refer to appropriate guidance including the United States Army Corps of Engineers (USACE) ER 1110-2-1156 SAFETY OF DAMS -POLICY AND PROCEDURES (28 October 2011). This document provides guidance on tolerable risks, periodic inspection, periodic assessment, and the continuing evaluation of dam systems. Also, USACE document ER 1110-2-8157 RESPONSIBILITY FOR HYDRAULIC STEEL STRUCTURES (15 June 2009) provides additional inspection guidance.</p> <ul style="list-style-type: none"> <li>• Survey key rail dimensions at spillway bays with fixed hoists at 10-foot intervals from base of the slot to the top of stanchions. This survey is recommended, at a minimum, when gate bay guide rails undergo damage.</li> <li>• Inspect wheels and lateral bumpers at spillway bays with swing rails (both upper and lower segments) for damage. This inspection is recommended after gate damage has occurred or if an incident such as the swing rail collapse occurs where wheel alignment could be a contributing factor.</li> <li>• Inspect crane rollers (Crane 2 and Crane 3) to verify they are freely turning.</li> </ul>
<b>TTR2</b>	<p>Revise swing rail design to include the design criteria shown in USACE EM 1110-2-2610 (30 Jun 13) — Mechanical and Electrical Design for Lock and Dam Operating Equipment and ETL 1110-2-584 Design of Hydraulic Steel Structures (30 June 2014). The manual (EM) and technical letter (ETL) provide guidance for sizing and designing hoists and tracks.</p> <ul style="list-style-type: none"> <li>• Provide hoist stall capacity to the swing rail assembly and stanchion per the USACE ETL appendix on “Lift Gates”. The swing rail, as part of the safety of the dam, should be designed to withstand the hoist maximum lift load.</li> <li>• Consider the stanchions and swing rail assemblies as Hydraulic Steel Structures (HSS) per USACE design criteria and thus they should be subject to periodic inspection.</li> </ul>

	<ul style="list-style-type: none"> <li>Specify acceptable rail tolerances on design drawings per the USACE ETL, which states, “The designer should assure appropriate tolerances exist in the plans and specifications to effectively fabricate and erect HSS”.</li> </ul>
<p><b>TTR3</b></p>	<p>The following modifications to the swing rail have been or are being implemented by the PUD during the investigation for this report.</p> <ul style="list-style-type: none"> <li>adding a structural bolt to hold the rail in place at the locking pin hole</li> <li>adding a hold-down gusset plate to prevent the assembly from pulling out</li> <li>adding a rail splice plate at the rail gap (this currently may not be a under consideration due to operational concerns)</li> <li>opening the swing rail when performing a gantry crane lift</li> </ul> <p>These modifications should be analyzed based on the criteria discussed in items 1 and 2 above. Alternatively, or in addition, installation of load limiting switches on the gantry cranes to limit their maximum lift is recommended for consideration.</p>
<p><b>Recommendations for District Consideration</b></p>	
<p><b>TTRC1</b></p>	<p>The PUD should consider modifying Crane 3 block leaders to allow them to travel across rail gaps with slight misalignment. By grinding a larger radius into the top of the leader blocks, the ability of the hoist to travel across rail gaps with misaligned rails will be increased. This recommendation may be applicable to Crane 2 if it has similar geometry.</p>
<p><b>TTRC2</b></p>	<p>The PUD should also consider eliminating the need for a swing rails along the spillway altogether, as this may, in the long run, prove to be the safest and most economical solution. The swing rail can be eliminated with any of the following alternatives:</p> <ul style="list-style-type: none"> <li>Lift the entire segmented gate out of the slot above the dam deck (roadway), from the top of the gate. This would eliminate the need for guide rails. This will require new permanent hoists and towers.</li> <li>Install an emergency spillway. This would eliminate the need to fully remove the gates.</li> <li>Extend the stanchions and rail guides so the gates can be fully removed from the slots and possibly remain on top of the dam.</li> </ul>

<b>WD Associates</b>		
<b>Recommendations</b>		
	<b>Identified Cause</b>	<b>Recommendations</b>
<b>WDR1</b>	<p>Read “Extent of Condition” Section on page 5-6 for full description.</p> <p>The extent of condition includes all lifting activities using gantry and bridge cranes.</p>	<p>Establish operating procedures for bridge and gantry crane lifts to ensure that a “safe zone” is established, access is restricted, and a spotter or other crew member is assigned to maintain an overall lift perspective.</p>
<b>WDR2</b>	<p>Failure to promptly and formally document and, as necessary, address through training and/or operational practices the swing rain-related safety concerns.</p>	<p>Conduct an independent survey or assessment of CCPUD personnel at all facilities to:</p> <ol style="list-style-type: none"> <li>1) Determine the degree of employee awareness of and engagement in the IRIS Reporting System,</li> <li>2) Assess the frequency with which employees currently document safety concerns; and</li> <li>3) Perform a data review of IRIS concerns to ensure that appropriate actions have been taken by the District to resolve and institutionalize similar safety concerns.</li> </ol> <p>Based on the results of the assessment, determine if additional actions are required to address the root cause concerns.</p>
<b>Recommendations for District Consideration</b>		
	<b>Identified Cause</b>	<b>Recommendations to Consider</b>
<b>WDRC1</b>	<p>Failure to promptly and formally document and, as necessary, address through training and/or operational practices the swing rain-related safety concerns.</p>	<p>Develop a standard lift plan for moving fixed hoist gates with gantry cranes that includes:</p> <ul style="list-style-type: none"> <li>- Analysis of the risks associated with the lift</li> <li>- Mitigating actions for identified risks</li> <li>- Requirements to establish a “safe zone” for non-lift crew members.</li> </ul> <p>Requirements to assign either a spotter, or a crew member with the responsibility to maintain an overall lift perspective</p>
<b>WDRC2</b>	<p>Same as WDRC1</p>	<p>Revise CCPUD Safety Program requirements for gantry and bridge crane operations to:</p> <ul style="list-style-type: none"> <li>- Establish a safe zone for all lifts;</li> </ul>

		<ul style="list-style-type: none"> <li>- Provide a designated crew member to either function as a spotter or maintain an overall lift perspective; and</li> </ul> <p>Provide controls to restrict access by non-lift personnel.</p>
<b>WDRC3</b>	Same as WDRC1	<p>Revise the Spillway OMI to include the following:</p> <ul style="list-style-type: none"> <li>- Procedure for operation of fixed hoist gates using a gantry crane.</li> </ul> <p>Actions to open the swing rails when lifting a fixed hoist gate equipped with swing rails using a gantry crane.</p>
<b>WDRC4</b>	Same as WDRC1	<p>Develop District standards for “what good looks like” for PTP conduct. At a minimum:</p> <ul style="list-style-type: none"> <li>- Focus on identifying and mitigating job risks</li> <li>- Provide clear attributes of a good PTP (“What good looks like”)</li> <li>- Provide expectation to validate that work-site conditions are consistent with the PTP discussion for cases where the PTP is not conducted in the work area</li> </ul>
<b>WDRC5</b>	Same as WDRC1	<p>(All parts of this action are required to be completed before action is closed)</p> <ol style="list-style-type: none"> <li>1) Once the previous action has been completed (PTP Standards), gain alignment and agreement from supervisors and managers that they understand and will enforce the standard with their workers.</li> <li>2) Communicate the PTP Standards to Foremen and work crews using multiple methods and media.</li> <li>3) Develop a plan to observe and reinforce worker behaviors of “what good looks like” for PTP conduct (with emphasis on risk recognition/mitigation). At a minimum, this plan should include:             <ol style="list-style-type: none"> <li>a. Defined field observation attributes for managers and supervisors’ use during observations.</li> <li>b. Involvement of an independent Subject Matter Expert (SME) to perform paired observations and reinforce “what good looks like”.</li> </ol> </li> </ol>

		<ul style="list-style-type: none"> <li>c. Defined expectations for the number, frequency, and targeted groups for observations.</li> <li>d. Defined exit criteria for when the desired PTP behaviors are anchored in the organization and the formal observation plan is no longer warranted. This should include criteria for periodic observations to maintain behaviors.</li> </ul> <p>4) Develop metrics to track and trend results of the observations. Metrics should include indicators showing desired PTP behaviors.</p> <p>5) Conduct a check and adjust activity (assessment) to determine if desired behaviors have been anchored based on the exit criteria developed in the Plan.</p>
<b>WDRC6</b>	Same as WDRC1	Continue implementation of Human Performance Improvement (HPI) tools at the District.
<b>WDRC7</b>	<p><b>Contributing Cause 1:</b>          Job planning did not ensure adequate coordination of the gate movement for testing.</p>	<p>Develop and implement job planning requirements and standards to ensure that formal job planning is performed for jobs that:</p> <ul style="list-style-type: none"> <li>- Perform activities not addressed by OMI's, procedures, work instructions, or lift plans;</li> <li>- Require coordination of multiple work groups;</li> <li>- May impact dam operations;</li> <li>- Are not routinely performed; or</li> <li>- Present a high level of risk due to the presence or suspected presence of a known hazard (such as asbestos, harmful materials, chemicals, etc.).</li> </ul> <p>At a minimum, job planning activities should include:</p> <ol style="list-style-type: none"> <li>1) Task reviews and walk downs to identify and mitigate hazards and risks associated with the job;</li> <li>2) Resource requirements including personnel, tools, equipment, and oversight</li> <li>3) Coordination requirements when multiple work groups are involved;</li> </ol> <ul style="list-style-type: none"> <li>- Instructions for job conduct;</li> </ul>

<b>WDRC8</b>	<b>Contributing Cause 2:</b> The swing rail design presented an unrecognized risk to personnel safety.	- Perform the actions recommended in the Tetra Tech report or developed by the District to correct the design of the swing rails to ensure that it will not become dislodged from its supports during gate movement operations.
<b>WDRC9</b>	<b>Contributing Cause 3:</b> The assignment of a three-person crew required the use of a “working foreman”.	Evaluate the practice of using working foreman and determine actions to either:  1) Discontinue its use as a normal District practice, or 2) Provide compensatory actions to ensure adequate oversight and overall job perspective. One potential solution is to use a graded approach to job supervision so that higher risk jobs have a non-working foreman, while lower risk or routine work can be performed using a working foreman.

## V. CONCLUSION

The June 13, 2018 incident at Rock Island Dam resulted from a weakness in the design of the swing rails deployed at eleven gates along the spillway that, until recently, appeared to have gone undetected for almost 25 years, until it tragically and suddenly led to an incident that claimed the life of Eddie Bromiley. As noted above, we were unable to determine whether the design originated within or outside the District. Our investigation and accompanying technical analysis, performed by an engineering firm with extensive experience in dam design and operation, concluded that the most probable explanation for the swing rail becoming detached and falling on June 13 was a slight rotation of Gantry Crane 3’s north hoist block in its downstream track as the block began to lift after engaging Gate 17’s north hook, which, in turn, caused the hoist block’s leaders to catch what is believed to have been the horizontally misaligned bottom edge of the north “swing rail,” lifting the rail until it became dislodged from its upper and lower hinge assemblies, falling to the spillway deck.

Our investigation also determined that there is credible evidence that a District employee first raised a concern with swing rail safety in the mid-1990s, but that no contemporaneous written documentation of any such concern was recorded, no service request submitted by the employee (or anyone else aware of the concern), nor written operational procedure adopted to address the concern on a going-forward basis. Instead, information regarding the potential safety concern was disseminated only verbally among relevant Rock Island personnel and ceased sometime prior to the June 13 incident. Our HPI consultant identified this informal and ultimately ineffective reliance upon dissemination of safety concerns via “tribal knowledge” to be a root cause of Technician Bromiley’s death. Regrettably, no one involved in any facet of the June 13 incident, nor anyone else we interviewed prior to December 3 as part of our

investigation, had ever previously -- directly or indirectly -- been made aware of such concerns or recognized or reasonably anticipated the possibility of risk posed by the specific combination of design and operational variables at play during the test lift of Gate 17 on the day of the incident.

We urge the District to adopt the affirmative recommendations of our expert consultants and also to seriously consider adopting their suggested modifications to the District's current engineering and operational practices and procedures.

HM:pl

Attachments

## **ATTACHMENT A**

James is experienced in providing structural analysis, design, and project management services. His academic research background includes finite element methods and nonlinear stability. James has developed methods for designing large-diameter steel encased reinforced concrete shafts. He has extensive experience in soil-structure interaction analysis and has performed advanced seismic analyses using nonlinear time history methods.

James' professional experience includes the design and retrofit of buildings, locks, dams, bridges, tunnels, and marine structures and extensive design work for floating, float-in structures. Structure types also include in-the-wet hydraulic steel and concrete structures such as floating lock guide walls, dams, and gates.

James has completed a significant amount of work on high profile projects for the United States Corps of Engineers (USACE) and his diverse experience includes habitation modules for the United States Space Station.

He is a respected resource for clients' structural needs.

## PROJECT EXPERIENCE

### **2015-Current IDC for Engineering, Design and Related Services for the Great Lakes and Ohio River Division to Include the Dam Safety Modification Center of Expertise, USACE Huntington District**

James is the Contract manager for this ongoing five-year, \$10M IDIQ contract. James works with task order project managers to assign the correct resources to the project, maintains contractual communications with the district, and insure work products meet the task order scope of work.

### **2009 - 2014 IDIQ A-E Contracts for Engineering Design and Related Services, Pittsburgh District**

James was the Contract manager for this five-year, \$10M IDIQ contract. James worked with task order project managers to assign the correct resources to the project, maintains contractual communications with the District, and insures work products meet the task order scope of work.

### **Lock 21 Submergible Tainter Gate, USACE Rock Island District (2018)**

James reviewed the hydraulic modeling approach and the hydraulic modeling results. He developed the procedures for evaluating the potential for hydraulic - structure interaction due to vortex shedding of the gate.

### **Gowanus Canal and Newtown Creek Storm Surge Barrier Studies; New York City Economic Development Corporation; New York, NY (2016)**

Responsible for storm surge barrier design.

## EDUCATION

MS, Civil Engineering, University of Washington (1991)

BS, Civil Engineering, University of California (1985)

## REGISTRATION/CERTIFICATION

Professional Engineer, Civil: LA License No. PE.0035319 (2010)

Professional Engineer, Civil: WA License No. 31737 (1994)

## YEARS OF EXPERIENCE

29 years

## YEARS WITH TETRA TECH

24 years

## OFFICE LOCATION

Bellevue, WA

## AREAS OF EXPERTISE

Floating, Float-In, & In-The-Wet Hydraulic Structures

Floating Lock Guide Walls

Structural Analysis

Earthquake Engineering

Foundation Engineering

Cold-formed Steel Design

Reinforced Concrete Design

Boat Locks

Bridges

**Dahla Dam Improvements Phase One; USACE, Middle East District; Kandahar Province, Afghanistan, (2015)**

James was responsible for technical reviews and quality control of the design of the replacement and expansion of the outlet works at this 50m earth embankment dam in Afghanistan. The work includes the design of a new 4.6m penstock, a new valve house with two 1700mm fixed cone valves, a new energy dissipation system, and the inspection and rehabilitation of the existing intake roller gate.

**2010-2015 A-E Services for IDIQ Contract for Independent External Peer Reviews within The USACE Civil Works Mission Boundaries; USACE, Louisville District (2015)**

James serves as Contract Manager for this \$7.2M IDIQ contract for this ongoing contract. He has assigned task orders to contract managers and maintains communications with the District on the proposal process, review, and ACASS ratings. James works with the project managers and helps them staff the projects consistent with the contract requirements and the task orders' scope of work.

**Keystone Dam Bridge Replacement IEPR; USACE, Tulsa District; Keystone, OK (2015)**

James managed a team of experts to assess, analyze, interpret, and evaluate design/engineering and construction criteria through a process known as Type II Independent External Peer Review (IEPR) Safety Assurance Review (SAR) for the Keystone Dam Bridge system during design and construction phases of the project.

**Panama Canal Third Set of Locks Design-Build Project; Panama Canal Authority; Cocolf and Gatún, Panama, (2014)**

James is the Senior Technical Reviewer for this mammoth project that involves in complex, innovative designs. Tetra Tech Bellevue Design Center's efforts on the Panama Third Set of Locks Project include the approach structures, the water saving basins, conduits, trifurcations and valve structures, and the wing walls inlet and outlet monoliths for both the Atlantic and Pacific Lock Complexes. The seismic analyses of these structures is a nonlinear time history analysis that includes the hydrodynamic effects of chamber water, yielding backfill, nonlinear foundation interaction, and accounts for the surrounding large concrete monoliths that affect the seismic motions.

**Neptune Sheet Pile Wall Condition Assessment; Port of Metro Vancouver; Vancouver, BC (2013)**

Project Manager/Lead Structural Designer: James developed a data analysis model/failure predictive model for the Port of Metro Vancouver, Canada's Neptune Sheet Pile Wall. Through a thorough risk assessment and development of mitigation measures, James performed a life-cycle cost analysis comparing multiple alternative mitigation strategies for this aging structure and provided a 50-year asset management plan that included annual treatment details to maintain the reliability of the walls in question. The result: the Port of Metro Vancouver realized an immediate cost savings of \$3 million less than an initial estimate of \$3.5 million in repairs by another consultant. Services also included the preparation of rehabilitation design and tender documents and field construction services.

**East Corridor High Capacity Transit Phase Two; Sound Transit; King County, WA (2012)**

Seismic Manager 2009-2011 who managed a team of six co-located engineers. Performing moving load dynamic analysis to evaluate rider comfort for a light rail vehicle passing over the transition bridge span onto a floating bridge for Sound Transit's Light Rail study. He also completed the seismic assessment and retrofit report for the Segment A bridges to carry the light rail vehicle. The analysis was a nonlinear soil structure interaction time history analysis. James incorporated column nonlinear moment curvature relations into the finite element time history analysis. His analysis also accounted for foundation softening due to the displacement demands. Owner: Sound Transit.

**Greater Mississippi Basin Post Flood Assessment ATR; USACE, Louisville District; Mississippi River Basin, MS (2012)**

James managed this project to provide an expert for the Risk Management Center to review the Greater Mississippi Basin Post Flood Assessment study. The system is comprised of numerous dams, levees, floodways, and channel

improvement projects within the watershed. The purpose of the assessment is to examine, assess, and document performance of the system during the 2011 floods and make recommendations to improve overall system performance with due consideration for local, sub-regional, inter-regional, and national perspectives.

**Bolivar Dam Risk Analysis Quality Control and Consistency Review; USACE, Louisville District; Sandy Creek, OH (2012)**

James managed this project to provide the Risk Management Center an expert to review the baseline risk analysis report for Bolivar Dam.

**Inner Harbor Navigation Canal (IHNC) Lake Borgne Surge Barrier; USACE, New Orleans District; Lake Borgne, LA (2012)**

Design Manager 2008-2010 for the largest civil works design-build contract led by the USACE for a hurricane risk reduction flood barrier at the Inner Harbor Navigation Canal near New Orleans. Managed a team of over 60 designers and delivered more than 40 contract packages directly to the client. Led the development of the design criteria for structural, civil, mechanical, and electrical disciplines. Also led design reviews of all features for conformance with the design criteria and owner's performance requirements. Ensured designs met USACE's specific hurricane surge barrier requirements as well as durability and life cycle requirements. Designed the U-shaped, float-in section of new lock chamber. Performed buoyancy calculations, floating stability calculations for float out and set down, and reinforced concrete design. Prepared contract drawings.

**Service Tunnel Rehabilitation at Sea-Tac Airport; Port of Seattle; SeaTac, WA (2012)**

James was the Project Manager for providing an initial seismic assessment of a cut and cover tunnel and elevated roadway at the Seattle-Tacoma International Airport. The tunnel analysis was based on an applied strain methods as outlined in the Federal Highways Administration Seismic Retrofitting Manual for Highway Structures. Analysis of the central core of the tunnel utilized spectral analysis and pushover analysis. Assessment of retaining walls was based on pseudo-static analysis.

**Engineering and Operational Risk and Reliability Analysis; USACE, Pittsburgh District; Various Locations, PA (2009)**

As Project Manager, James managed Independent Technical Review (ITR) of risk methodology for levees and dams produced by the USACE. The review team consisted of international experts in the fields of dam safety and levee safety. Final report issued panel's findings and recommendations

**Finite Element Modeling and Analysis of Emsworth Dam; USACE, Pittsburgh District; Ohio River, PA (2008)**

As Lead Design Engineer, James worked on a global finite element analysis model to determine loads for the filling and emptying F/E system. A local stress analysis model of critical components was used to analyze fatigue and failure modes, such as cracking and failure at critical connection points, mechanical component failure, and effects on the overall system reliability. This risk-based evaluation will help the District prioritize repairs and maintain the facility's operation.

**Charleroi Locks and Dam Lower Guard Wall; USACE, Pittsburgh District; Monongahela River, PA (2008)**

As Design Engineer, James developed design criteria for the new lower guard wall at Charleroi Locks and Dam. The new lower guard wall design consisted of precast wall panels supported by large diameter drilled shafts. The drilled shaft was socketed into rock and encased in a precast concrete shell, which was designed to allow accurate placement on the supporting drilled shafts, to have a finished and armored surface facing the lock approach and to be grouted solidly in place.

**Light Rail Transit Civil Facilities Engineering Services; Sound Transit; Seattle, WA (2007)**

In his role as Project Engineer, James performed general construction and design support for Sound Transit's light rail installation in Seattle, WA.

**Museum Plaza Building Flood Walls; Kendall/Heaton Associates; Louisville, KY (2007)**

This project integrates with and requires modification to portions of the flood protection system that protects downtown Louisville from flooding along the Ohio River. As Design Engineer, James participated in the design of replacement and relocation of two floodgates, one across Washington Street and another at Muhammad Ali Center and associated floodwalls.

**Charleroi Land Wall Design; USACE, Pittsburgh District; Monongahela River, PA (2007)**

As Senior Structural Engineer, James led the brainstorming meeting to review the shoring wall design and develop alternative designs for construction of the new chambers at Charleroi Locks and Dam. James participated in developing concepts for new wall types including slurry wall, secant wall, ground improvement, and other wall types.

**Dashiels Locks and Dam Risk and Reliability Assessment; USACE, Pittsburgh District; Ohio River, PA (2007)**

As Project Manager, James developed structural risk and reliability models for Dashiels Locks and Dam using @RISK software to evaluate the overall structural reliability of one typical dam section, and two sections abutments under various pool events. The reliability information was used in the USACE Pittsburgh District to prioritize dams requiring initial investigations and to prioritize funding for critical repairs/replacement and protect human life.

**Chickamauga Lock Upstream and Downstream Approach Walls; USACE, Nashville District; Tennessee River, TN (2007)**

As Project Manager, James managed the design of the upper and lower approach walls at the new Chickamauga Lock to the 100 percent level of plans and specifications. The design accommodates the unique site geotechnical features by utilizing drilled shaft foundations in the relatively deep sand and cobble layer upstream and concrete filled, steel shell gravity piers that bear on the surface rock layer downstream. The walls are constructed from offsite prefabricated beams that are stacked on the piers. The beams are ten-foot by ten-foot post-tensioned box beams with two-foot-thick impact walls. The walls are heavily reinforced to resist impact from barges. The beam span approximately one hundred feet between piers. The end of each approach wall is protected by a nose pier structure that is shaped to divert head-on barge collisions away from the wall. The beams are supported on elastomeric bearing pads. Rebound forces from the barge collisions are resisted with prestressed bars that pass through the ends of the beams and into the piers. Provisions for skirts under the beams to control cross channel flow are there in case it is decided skirts are needed at a later date to aid navigation. In general the beams are a hollow box cross-section. The walls and slabs, however, thicken near the ends of the beams where a solid end block is located. The thickened concrete is optimized for stress transfer to the supports at the ends of the beams. The solid beam end-blocks are minimized to reduce the beam weight but still provided adequate strength to rest post-tensioning and bearing loads. Tetra Tech completed a design documentation report, drawings and specifications for this work.

**ETL 1110-2-564 Selection and Design of Approach Walls; USACE, Huntington District; Huntington, WV (2007)**

In his role as Design Engineer, James contributed to developing an engineering technical letter documenting the process for selecting and analyzing dam approach walls. The ETL emphasized construction methods and impact to navigation.

**West Bank and Vicinity Hurricane Protection, Bayou Segnette Pump Station and Company Canal; USACE, New Orleans District; Orleans Parish, LA (2007)**

As Design Engineer, James produced drawings, plans and specifications for protection to El 8.5 NAVD88 at the Old Bayou Segnette Pump Station and Company Canal Inlet in Jefferson Parish. Additionally, he designed floodwall to tie into an adjacent floodgate located in Bayou Segnette State Park. Construction was completed in 2008.

**Chickamauga Lock Miter Gate Anchorage Replacement Design; USACE, Nashville District; Tennessee River, TN (2006)**

As Project Manager, James coordinated Tetra Tech engineering services for the design, construction plan preparation, and detailed drawing notations for replacement gate anchorage for the Chickamauga Lock lower miter gates. The new Chickamauga miter gate serves the 100-foot-wide lock. The upstream gate is 31 feet high while the downstream gate is 72 feet high.

**Chickamauga Upstream and Downstream Miter Gates DDR and P&S; USACE, Nashville District; Tennessee River, TN (2006)**

James was the Project Manager for the design of miter gates at the new Chickamauga Lock. Design innovations include new diagonal details for fatigue resistance and new removable pintle design. Tetra Tech engineers evaluated and adapted upstream and downstream Kentucky Lock miter gate designs to produce a Design Documentation Report DDR and produced complete plans, specifications, and MCASES estimate. The miter gates were analyzed and designed by Tetra Tech using CMITERW-LRFD. In addition, Tetra Tech used a finite element model to verify the behavior of the gates, complete estimates of appropriate tensioning of the diagonals, and check the stress levels of the structural members. Fracture critical members were identified and indicated on the contract plans.

**Chickamauga Lock Replacement Upstream and Downstream Approach Walls; USACE, Nashville District; Tennessee River, TN (2006)**

James served as Task Order Manager for the design of upstream and downstream approach walls for the Chickamauga Lock replacement. This contract carries forward to final design the recommendations of the Alternative Study. Approach walls are designed for anticipated environmental loads, barge impact, earthquake, and construction loads. Nose piers were designed at the end of the approach walls to protect them from head-on barge collisions. Analysis of the walls included application of environmental loads such as river flow, wind, and temperature as static loads; earthquake is modeled with a dynamic mode shape method; and barge impact was investigated as a static load for local effects and as a dynamic load to capture global effects.

**D700 Support during Construction; Sound Transit; Seattle, WA (2006)**

James was the Structural Engineer providing construction support. His work included reviewing shop drawings, answering requests for information, and providing site inspections for the aerial structures at the maintenance yard and leading to the Beacon Hill tunnel. Construction was completed in 2008.

**Olmsted Lock and Dam Upper and Lower Approach Walls Construction Services; USACE, Louisville District; Ohio River, IL (2005)**

As Structural Engineer, James provided engineering during construction for the revision of lower land wall handrails and wall armor, shop drawing and submittal review, requests for information, value engineering change proposal review, site trips, and machinery house crossover bridge design. Construction was completed in 2005.

**Monongahela River Locks and Dam No. 3 Risk and Reliability Assessment Study; USACE, Pittsburgh District; Pittsburgh, PA (2005)**

As Structural Project Manager, James assessed the effect of apron scour holes on dam stability using finite element analysis.

**C700 International District to East of I-5; Sound Transit; Seattle, WA (2005)**

As Structural Engineer, James provided design for structural elements, including foundation design for the aerial and transition bridge structures. This included drilled shaft foundation design for multiple bridge structures supporting light rail vehicles on continuously welded rail. The design incorporated both liquefaction potential of the area and the presence of the continuously welded rail linking the aerial structures together. Construction was completed in 2008.

**2002-2004 IDC for Inner Harbor Navigation Canal Lock Replacement; USACE, New Orleans District; New Orleans, LA (2004)**

As Project Engineer for the design of U-shaped float-in section of new lock chamber, James was responsible for buoyancy calculations, floating stability calculations for float out and set down, reinforced concrete design, and preparation of contract drawings.

**Charleroi Lower Floating Guard Wall Study; USACE, Pittsburgh District; Monongahela River, PA (2004)**

James was Project Engineer for the final design of a floating lower guard wall at Charleroi Lock and Dam. The lower guard wall was composed of a post-tensioned concrete pontoon with intermediate transverse bulkheads, fabricated at a dry dock facility, and floated to the project site. A drilled-shaft-supported nose pier was constructed at the downstream end of the wall, and the pontoon was installed between the nose pier and the new river wall. The nose pier and new river wall act as both guide and support structures. The nose pier protects the pontoons from longitudinal barge impacts. The pontoons are locked in position with removable closure blocks and locking keys. The entire wall was designed to be constructed in-the-wet without a cofferdam. James was responsible for preparation of a lessons-learned report and a design report.

**Sitka Floating Dock; Samson Tug & Barge; Sitka, AK (2003)**

As Structural Engineer, James designed the marine fender system to absorb impact collisions.

**De Diego Bridge Modifications; USACE, Jacksonville District; San Juan, PR (2002)**

James was Structural Engineer for final design and plans, specifications and estimate for an upgrade of the two De Diego Expressway Bridges. This project was part of the Rio Puerto Nuevo Flood Control Project in San Juan, Puerto Rico. The project involved a four-lane and a five-lane bridge over the Rio Puerto Nuevo and the De Diego Expressway, a major artery into and out of downtown San Juan. The Puerto Rico Highway and Transportation Authority PRHTA required that no interruption to traffic occur as a result of the upgrade of these two bridges.

**Additional Combination of Lock Water Study Basin Task Two; Panama Canal Authority (ACP); Cocolí and Gatún, Panama, (2002)**

James was Structural Engineer for the preparation of concept designs for four, water-saving basin configurations:

- Three-lift, lock structure: side-by-side water savings basins to one side of lock 50 percent water savings
- Two-lift, lock structure: side-by-side water savings basins to one side of lock 60 percent water savings
- Three-lift, lock structure: side-by-side water savings basins on both sides of lock 60 percent water savings
- Two-lift, lock structure: stacked water savings basins on one side of lock 50 percent water savings

For each configuration, he developed layouts and section views of the basins and culvert sizes as well as orientation and relationship to lock structures.

**Houma Navigation Canal Lock Project Alternative Design Report; USACE, Vicksburg District; Houma Canal, LA (2002)**

James was Structural Engineer for the preliminary design for all of float-in gate monolith alternatives. Tetra Tech developed all in-the-wet construction methodologies, analyzed construction feasibility, prepared cost estimates, and issued the design documentation for the float-in work. The lock alternatives under consideration in this Phase I study varied from 56 feet wide by 600 feet long to 200 feet wide by 1,200 feet long. For lock configurations less than 200 feet wide, a 200-foot-wide flood gate adjacent to the lock was studied. All lock configurations included a normal depth of 20 feet over the gate sill, the current authorized depth of the canal. This project is an integral feature of the Morganza-to-the-Gulf Hurricane Protection project. At 200 feet wide, this would be the widest navigable lock ever built in the United States.

**Houma Navigation Lock Design Report, Plans and Specifications; USACE, New Orleans District; Houma Canal, LA (2001)**

James was Structural Engineer for preliminary design details for an offsite prefabricated float-in lock and floodgate. In this role, he evaluated and compared float-in design with cast-in-place alternatives. Various lock and floodgate size combinations were developed and evaluated. The float-in lock monoliths were constructed at an offsite graving yard under precast shop conditions. The graving yard is located near a navigable channel that was used to transport the monoliths to the lock site.

**Study of Locks Water Saving Basins; Panama Canal Authority (ACP); Balboa, Panama, (2001)**

Structural Engineer for the preparation of concept designs for four configurations for water saving basins:

- Three lift lock structure: side by side water savings basins to one side of lock 50 percent water savings
- Two lift lock structure: side-by-side water savings basins to one side of lock 60 percent water savings
- Three lift lock structure: side-by-side water savings basins on both sides of lock 60 percent water savings
- Two lift lock structure: stacked water savings basins on one side of lock 50 percent water savings.

Also developed layouts and section views of the basins and culvert sizes, and their orientation and relationship to lock structures for each configuration.

**Kentucky Lock Addition Upstream Approach Walls; USACE, Nashville District; Tennessee River, KY (2001)**

As Structural Engineer, James developed stability and engineering analysis; and pontoons, nose pier structures and guide recesses design; time history analysis; analysis of upper approach wall components; dynamic analysis of pontoons; and thermal analysis of concrete structures. His work supported an addition of a 110-foot by 1,200-foot lock chamber landward of the existing lock.

**Renton Paccar Office Seismic Review; PACCAR, Inc.; Renton, WA (2001)**

As Project Engineer, James conducted a seismic evaluation of the Renton office building after the 2001 6.8-magnitude earthquake.

**Kentucky Lock Miter Gates Design Final Review; USACE, Nashville District; Tennessee River, KY (2000)**

James was Project Engineer for final design review of the miter gate structures used in the Kentucky Lake Dam Locks Replacement project. He reviewed the structural analysis including skin plate, intercostals, diaphragms and stiffeners; girders; quoin posts and thrust diaphragms; gudgeon pin hood and anchorage; pintle assembly; operating strut assembly; diagonals; miter and wall quoins; walkway seat and jack points.

**P&L Railroad Phase Two Construction Documents; USACE, Nashville District; Tennessee River, KY (2000)**

James was Structural Engineer for the analysis and design for 11 pier foundations and 11 pier columns with different geotechnical parameters and rock surfaces. He designed a round, precast shell to facilitate the caps being built in-the-dry without cofferdam; detailed all shaft foundations, pier caps and columns; and prepared cost estimate to compare with the MCACES done by others. In addition, he prepared specifications for drilled shaft foundations and concrete caps - precast bath tub shells, concrete columns and column caps - in conjunction with the P&L Railway Bridge over the Tennessee River.

**Yellow Creek Channel Improvements Drilled Shaft Retaining Wall "C"; USACE, Nashville District; Middlesborough, KY (2000)**

James was Project Engineer for an analysis of retaining wall "C" at Middlesborough. The work determined size and reinforcing necessary for the structural shafts and cap beam. Construction was completed in 2001.

**Rio Puerto Nuevo Main Channel Wall System Value Engineering Study; USACE, Jacksonville District; San Juan, PR (2000)**

James provided QA/QC for the VE report that documented an investigation of several alternatives for the Rio Puerto Nuevo, Main Channel Wall System, reach 2D. This reach represented approximately 11,800 lineal feet of wall with an average exposed face of approximately 26 feet. This work was a portion of the Rio Puerto Nuevo Flood Control Project. James completed three primary tasks during the development of this report: reanalyzing the master pile wall, analyzing/developing alternative wall designs, and preparing a final report. Design development included structural analysis, capital cost, maintenance costs, construction sequencing, utility relocations, and real estate requirements. The task also included the solicitation and evaluation of proprietary designs.

**Kentucky Lock Addition Floating Caisson Plans and Specifications; USACE, Nashville District; Tennessee River, KY (2000)**

Project Engineer for design documentation for the fabrication and construction of a second floating caisson for the Nashville District. The design work for the new floating caisson included an increase of an additional 18-inch extension in height in the vertical position, the provisions for lock dewatering pipes on the caisson, provisions for caisson installation at any Tennessee or Cumberland River Lock without modification to the lock structures, and analyses for flotation and rotation.

**Kentucky Lock Addition Floating Caisson Design; USACE, Nashville District; Tennessee River, KY (1999)**

To support the fabrication and construction of a second floating caisson for the Kentucky Locks Project, James served as Engineer for design documentation. The design work included an increase of an additional 18-inch extension in height in the vertical position, provisions for lock dewatering pipes on the caisson, provisions for caisson installation at any Tennessee or Cumberland River Lock without modification to the lock structures, and analyses for flotation and rotation.

**Kentucky Lock Miter Gates Design Review; USACE, Nashville District; Tennessee River, KY (1999)**

As Project Engineer, James reviewed the 75 percent completion phase of the feature design documentation for the miter gate structures to be used in the Kentucky Lake Dam Locks Replacement project. He reviewed the structural analysis for the design of the miter gate including skin plate, intercostals, diaphragms and stiffeners; girders; quoin posts and thrust diaphragms; gudgeon pin hood and anchorage; pintle assembly; operating strut assembly; diagonals; miter and wall quoins; walkway seat and jack points.

**Kentucky Lock Preliminary Design of Addition Upstream Floating Approach Walls; USACE, Nashville District; Tennessee River, KY (1999)**

James was Project Engineer on the feasibility design of upstream floating approach walls for the Kentucky Lock Addition. This project added a 110-foot by 1,200-foot lock landward of the existing 110-foot by 600-foot lock at the Kentucky Dam. James evaluated scope and estimated required engineering and drafting efforts.

**Olmsted Lock and Dam Upper and Lower Approach Walls; USACE, Louisville District; Ohio River, IL (1998)**

As Structural Engineer, James was responsible for the design of post-tensioned, concrete pontoons. He developed 3D finite element models to evaluate dynamic response to seismic and impact loads. He also developed soil/structure interaction model in STRUDL based on SASSI output matrices. Construction for this project was completed in 2005.

**SR 526 and I-5 Interchange and Flyover Ramp; City of Everett; Everett, WA (1996)**

As Structural Engineer, James designed the reinforced concrete for the bridge tunnel approach.

**The Dalles Dam Juvenile Fish Bypass Facility; USACE, Portland District; Columbia River, OR (1996)**

As Structural Engineer, responsible for the structural analysis of the outfall structure that consisted of a post-tensioned, cable-stayed, cantilevered bridge.

**West Point Treatment Plant and Fascia Wall; ; Seattle, WA (1995)**

Structural Engineer for the analysis and detailed design drawings of the fascia wall panels and their connections to the Hilfiker Wall System.

**Mt. Pinatubo Recovery Action Plan; USACE, Portland District; Mt. Pinatubo, Philippines, (1994)**

As Structural Engineer, James prepared preliminary design of various roller compacted concrete dams.

**SR 526/I-5 Interchange (see 9194); City of Everett; Everett, WA (1994)**

As Structural Engineer, James designed the reinforced concrete for the bridge tunnel approach.

**Hollywood and Vine Underground Transit Station; Los Angeles County; Los Angeles, CA (1993)**

As Structural Engineer, James provided design services for the Hollywood and Vine transfer station and crossover structure. He designed the entrance structure and the concrete bearing wall facility. This project was part of the METRO Red Line Project. The station is 520 feet long; the structure is 370 feet long and approximately 40 feet deep and 60 feet wide. Both station and structure were buried 15 feet below the surface of Hollywood Avenue. Work included all structural analysis, design and detailing for the station, crossover, and entrances.

**Bonneville Navigation Lock Fixed and Floating Guide Wall; USACE, Portland District; Cascade Locks, OR (1993)**

As Structural Engineer, James performed collision time history finite element analysis to develop design loads.

**SR 509: Pacific Avenue to East "D" Street PS&E Studies; ; Tacoma, WA (1992)**

As Structural Engineer, James designed the reinforced concrete design of the crossbeams.

---

## PREVIOUS PROJECT EXPERIENCE

**Bay Shore Boulevard Undercrossing; Caltrans; San Francisco, CA ()**

James was the Structural Engineer for the seismic retrofit of this reinforced concrete T-girder bridge.

**Boeing 4-81 and 4-82 Building; Renton, WA ()**

As Structural Engineer, James completed a seismic and gravity evaluation of the existing structure and proposed addition. The math model exceeded 30,000 frame elements.

**Boeing 40-24 Building; Everett, WA ()**

James was the Structural Engineer for the seismic and gravity evaluation of the existing building per 1988 UBC and Boeing Seismic Design Criteria. Substructuring methods were used to limit math model size (40-24 is part of the 747 Assembly Factory).

**Boeing Building 4-20 Wing Lift Facility; Renton, WA ()**

James was the Structural Engineer for the gravity and seismic analysis of the truss structure that supports heavy industrial cranes by finite element methods.

**Boeing Building 45-02; Everett, WA ()**

As Structural Engineer for the project, James completed the seismic analysis and retrofit design to Category I Boeing Seismic Design Criteria and UBC 1991 seismic criteria.

**Boeing Pallet Racks; Everett, WA ()**

James was the Structural Engineer for the seismic and gravity analysis to determine maximum shelf capacity of standard configurations of pallet racks. Stability analysis identified lateral torsion buckling of the columns as the controlling mode of failure.

**British Petroleum Skim Oil Tanks; North Slope, AK ()**

As Structural Engineer for the project, James conducted a seismic analysis on existing low pressure tanks to determine maximum operating capacity and identify failure mode.

**Central Hospital; Group Health Cooperative; Seattle, WA ()**

As Structural Engineer for the project, James completed the seismic analysis of a concrete shear wall building.

**Group Health Hospital; Group Health Cooperative; Seattle, WA ()**

As Structural Engineer for the project, James conducted a seismic analysis and finite element of computer seismic analysis to determine appropriate mitigation analysis. The analysis was conducted for their Central Hospital A/C wing remodel for Group Health Cooperative of Puget Sound. This 5-story reinforced concrete hospital building was built in 1959.

**Justin Drive Overcrossing; Caltrans; San Francisco, CA ()**

As Structural Engineer, James performed the seismic retrofit of this reinforced concrete box girder bridge.

**Reinforcement Cage Stability; Malcolm Drilling; , ()**

As Structural Engineer for the project, James determined critical buckling load for various configurations of reinforcement cages.

**Rocket Research Tilt-up Panel; Redmond, WA ()**

As Structural Engineer for the project, James determined the ultimate capacity of the existing wall to resist blast load. He utilized a time history analysis. Results verified with strain gauges.

**Rosalie Whyel Museum of Doll Art; Bellevue, WA ()**

James was the Structural Engineer for the preliminary design and analysis of the roof system.

**Route 134/710 Separation; Caltrans; Los Angeles, CA ()**

As Structural Engineer, James conducted the seismic retrofit of a seven-span box girder bridge.

**Space Station; NASA; Houston, TX ()**

As Structural Engineer for the project, James performed preliminary design of the habitation modules and support truss.

**Tyler Street Pedestrian Overcrossing; Caltrans; Los Angeles, CA ()**

James was the Structural Engineer for the seismic retrofit of this reinforced concrete box girder bridge.

---

## AWARDS

- "Outstanding Civil Engineering Achievement Award," Inner Harbor Navigation Canal (IHNC) Lake Borgne Surge Barrier, ASCE (2014)
- "Outstanding Project of the Year," Inner Harbor Navigation Canal (IHNC) Lake Borgne Surge Barrier, FIDIC (2014)
- "Engineering Excellence, National Finalist Platinum Award," Inner Harbor Navigation Canal (IHNC) Lake Borgne Surge Barrier, ACEC (2012)
- "Grand Conceptor Award, the top National Engineering Excellence Award," Inner Harbor Navigation Canal (IHNC) Lake Borgne Surge Barrier, ACEC (2012)
- "Honor Award," Bonneville Navigation Lock Fixed and Floating Guide Wall, USACE (1999)
- "Achievement Award," SR 526 and I-5 Interchange and Flyover Ramp, Washington Quality Initiative (1997)

---

## ADDITIONAL TRAINING

- Bentley InRoads Production Level Design Training, Bentley InRoads (2006)
- Drilled Shafts Specialty Seminar, Deep Foundations Institute (2006)
- The Marketing Engineer, ACEC Washington (2006)
- WSDOT Highway Runoff Manual Training, WSDOT (2006)
- Microstation V8 Training, (2005)
- Seattle Fault Scenario Conference, SEAW (2005)
- WSDOT Highway Runoff Manual Training, WSDOT (2005)
- CAiCE v10 Roadway Design Training, (2004)
- ACAD 2002-LDT3 Training, (2002)



1605 Dooley Road  
P.O. Box 187  
Whiteford, MD 21160  
Phone: 410-452-0055  
WWW.TEAMWD.COM

## RESUME

Frederic D. Lake, Jr.

**SUMMARY:** Performance Improvement Director, Corrective Action Program Manager, Contract Management, Root Cause Analysis, Self-Assessment, Licensing and Regulatory Affairs, System Engineering, and Emergency Preparedness.

**EDUCATION:** BA Degree in Organizational Dynamics - Immaculata College  
U.S. Navy Nuclear Power Training Program  
Certified Senior Reactor Operator (BWR) - Nine Mile Point Unit 2  
10CFR50.59 Evaluator  
Human Performance Evaluation System  
Equipment Failure Root Cause Analysis  
ASME Boiler and Pressure Vessel Code Section XI  
Principles of Instructional Design and Classroom Instruction

### EXPERIENCE:

#### **WD Associates, Inc.**

7/13 – Present

#### President

Responsible for overall operation of the company. Consulting services provider with primary emphasis in causal analysis, regulatory recovery, assessments, human performance, and training. Interface with senior station management to provide fact based insights into performance problems and develop effective and sustainable organization based solutions.

Areas of services provided include:

- Cause analysis mentoring and support
- Conduct of Cause Analysis Training for nuclear, fossil, and industrial facilities
- Corrective Action Program (CAP) assessments
- NRC 95001/95002/95003 inspection preparation and support
- Human Performance Improvement
- Organizational Effectiveness Evaluations



Frederic D. Lake, Jr.

4/12 – 7/13 Vice President – Business Development

**Arizona Public Service**

7/08 – 4/12 Director – Performance Improvement – APS Palo Verde Nuclear Generating Station

Director leading the implementation of the Corrective Action Program (CAP), Operating Experience (OE), Human Performance, Self-Assessment, Benchmarking, and Trending and Analysis Programs at Palo Verde.

Managed CAP production, causal analysis, and operating experience during station recovery efforts from NRC Reactor Oversight Process (ROP) Column 4. These efforts resulted in moving from ROP Column 4 to Column 1, clearing a long-standing substantive cross-cutting issue in the area of Problem Identification and Resolution (PI&R), clearing of an NRC Confirmatory Action Letter, and resolving INPO Areas for Improvement (AFI) in Causal Analysis and Operating Experience.

Active in the Corrective Action Program Owners Group (CAPOG) Steering Committee, Human Performance/Root Cause/ Trending (HPRCT), and the STARS Alliance CAP Excellence Initiative.

Winner of the APS Chairman's Award for 2009 for leadership in clearing INPO AFI's and helping the station to improve station performance as recognized in the 2009 INPO Assessment.

**WD Associates, Inc.**

7/96 – 7/08 Performance Improvement Consultant:

Representative assignments include:

- Arizona Public Service – Palo Verde Nuclear Generating Station
  - RCA and Apparent Cause (ACE) Training and Mentoring;
  - Corrective Action Review Board (CARB) Training and Mentoring;
  - 95003 NRC Inspection Preparation Support;
  - Developed a Leadership/Management Model and was instrumental in developing and conducting training for station leaders
- Exelon - Three Mile Island Nuclear Station:
  - RCA Team Leader;

Frederic D. Lake, Jr.

- CAP improvement initiatives including adequacy reviews, extent of condition reviews, and corrective action effectiveness reviews;
- Florida Power & Light – Turkey Point Nuclear Plant:
  - Assessment in preparation for NRC PI&R Inspection
  - Security Management on Shift Observation and Mentoring
- Dominion Power:
  - Root Cause support at the North Anna, Surry, and Kewaunee Nuclear Stations

Design Engineering – Fort Calhoun Station

Provided consulting services for resolution of NRC Generic Safety Issue (GSI) – 191; Duties included:

- Implementation of NRC Bulletin 2003-01 compensatory actions and response to NRC Generic Letter 2004-02;
- Performing engineering analysis of plant specific compensatory actions and post-accident containment water level;
- Development of Request for Proposals, and evaluation of proposals, for hardware modifications to resolve GSI-191;
- Containment walkdowns per NEI 02-01 guidance; and
- Development of a containment insulation inventory and containment insulation configuration controls.

These duties involve coordinating actions between plant departments and vendors, developing equipment specifications and commercial terms for replacement equipment, performing and reviewing calculations and engineering analysis, and verifying as-built plant configuration.

Project Manager, Plant Material Condition Assessment Project

Led a project team of ten individuals in the performance of plant material condition assessments for over 40 Exelon Power Fossil and Hydroelectric Generating Plants.

Major tasks included:

- Walkdowns of plant equipment to determine condition and document deficiencies. Over 50,000 plant components were assessed;
- Review of maintenance data;
- Tracking of Project costs and schedule variances;
- Maintenance of a detailed database containing the result of the plant walkdowns, testing, and maintenance reviews; and



Frederic D. Lake, Jr.

- Development of a risk based prioritization process that quantified each deficiency based on risk to power plant operations, and contribution of the deficiency to plant reliability, capacity, and heat rate.

Exelon Nuclear - Peach Bottom License Renewal Procedure Implementation Project

Team Leader for project that developed procedure and program changes to implement commitments made in the Peach Bottom License Renewal Application. This included review of Aging Management Evaluations and the License Renewal Application, and making necessary program and procedure changes to ensure compliance with License Renewal Commitments.

Department Director

Responsible for all company services rendered to a major utility client and its subsidiaries representing 50% of company business. Specifically, this entailed management of all aspects of a multi-year contract to a utility company as Preferred Provider of technical staff augmentation services.

Duties included management of company business functions as well as customer proposal and performance activities. Included are day-to-day monitoring and management of employee performance, management of contract issues, performance indicator reporting, recruiting, and ensuring that WD Management expectations are communicated to the work force.

Specific accomplishments included:

- Processed over 360 position requests at >98% fill rate and an average response time of 3.5 days.
- Retained over 60 percent of WD contract employees by placing them on assignments at multiple locations within the client utility.
- Documented savings delivered to the client of > \$4,000,000.00 during the contract period. This includes costs savings as a direct result of controlling labor costs, and proposing alternative, cost savings solutions to client Problems.

Also provided short term specialized services to the client including Root Cause Analysis, Management Assessments, Procedure Development, and Drill Monitoring Services.

Frederic D. Lake, Jr.

Project Manager, PECO Nuclear, Software Development Process Improvement

Coordinated efforts of a team to develop and implement a new Software Development Process, and associated procedures. These procedures integrated the software processes with the Design Change Process and ensured compliance with NRC Regulatory Guidance and Requirements, IEEE and ANSI Standards.

Software engineering process strategies were developed consistent with the SEI Software Capability Maturity Model (CMM Level 2). Trained PECO Nuclear workforce in the application of the new procedures and the new IS Process.

Licensing Consultant, Hope Creek & Salem Gen. Station, NJ

Member of a team tasked with drafting a reply to the 10CFR50.54 (f) letter regarding the adequacy and availability of design bases information. This required collecting information from Hope Creek and Salem to validate packages assembled to support PSE&G's response.

Lead Reviewer, Hope Creek Gen. Station, NJ

Member and Lead Reviewer for the Technical Specification Surveillance Improvement Project (TSSIP). Reviewed surveillance procedures to ensure compliance with Technical Specifications and Licensing Bases. Identified and provided recommendations to resolve noncompliant testing activities. Interfaced with Site Management to resolve noncompliance. Peer reviewed reports developed by other team members prior to being submitted to the PSE&G Project Manager.

**New York Power Authority**

1994 - 1996

Senior Licensing Engineer, J. A. FitzPatrick Nuclear Power Plant

Ensure compliance with the operating license, plant commitments, and NRC regulations. Duties include; preparation of submittals to the NRC, including amendments to the plant operating license and Technical Specifications; interfacing with the plant and NRC staff on licensing issues; Preparation and review of License Event Reports; and determining reportability per 10 CFR Parts 21, 50.72 and 50.73. Specific areas of responsibility include: Appendix J containment leak rate testing, ASME

Frederic D. Lake, Jr.

B&PV Code Section XI compliance, Station Blackout, and 24-month operating cycle implementation.

**General Physics Corporation**

1989 - 1994

Lead System Engineer, J. A. FitzPatrick Nuclear Power Plant

Coordinated the efforts of the ECCS systems engineers; ensured adequate resources available to support critical plant tasks; reviewed operability assessments and 10CFR50.59 reviews and screening; and coordinated between site departments to resolve emergent plant issues.

Systems Engineer, J.A. FitzPatrick Nuclear Power Plant

Resolved issues affecting system operability and reliability; improved system performance through use of plant and industry operating experience; performed engineering evaluations of systems and components to ensure design and operation consistent with plant's licensing basis and vendor recommendations; prepared and reviewed 10CFR50.59 evaluations; and reviewed licensing submittals, amendments and Technical Specifications. Additional duties included; Post Trip Review Team Member; logic system functional test and surveillance testing adequacy review; and resolution of plant restart issues.

Senior Reactor Operator (BWR) Certification Course

Completed a 26 week SRO/STA course at Nine Mile Point Unit 2.

Emergency Preparedness Support, Niagara Mohawk Power Corporation

Provide classroom instruction in off-site radiological dose assessment, Protective Action Recommendation, and emergency procedures. Wrote and presented instructional materials including lesson plans and tabletop drill scenarios. Developed and observed emergency preparedness drills and exercises at the Nine Mile Point Nuclear Station.

1980 - 1989

**United States Navy**

Served in the Navy Nuclear Power Program on submarine and prototype nuclear plants. Representative duties included training, examination and qualification of Naval Officers and General Electric engineers as nuclear supervisory plant personnel; coordination and documentation of work



Frederic D. Lake, Jr.

items during a prototype refueling overhaul; and coordination of electrical watch standing, operations and maintenance tasks assigned to the Electrical Division.

Served as Electrical Division Leading Petty Officer, Training Engineering Officer of the Watch, and Section Training Coordinator. As Training Coordinator, was directly responsible for the training of over 500 enlisted and commissioned students.

## **ATTACHMENT B**



November 19, 2018

Mr. Harold Malkin  
 Lane Powell  
 1420 Fifth Ave  
 Suite 4200  
 Seattle, WA 98111

Subject: Rock Island Dam –June 13, 2018 Incident at Spillway 17

## 1.0 Design Summary

### 1.1 Rock Island Dam Pertinent Data

Columbia River	River Mile 453.4
Constructed	1933, 6 additional units completed 1953, Second Powerhouse completed 1979
Owner	Chelan County PUD
Top of Parapet	El 620.0
Deck	El 616.0
Normal Full Pool	El 614.1
Normal Minimum Pool	El 610.1
Spillway	31 Gates, 1 Fish Ladder
Gate Bays 1-6	Deep Spillway Bays
Gate Bays 7-14	Shallow Spillway Bays
Gate Bay 15	Middle Fish Ladder
Gate Bay 16-25	Shallow Spillway Bays
Gate Bays 26-32	Deep Spillway Bays
Fish Passage Notch Gates	Bays 1, 16, 18, 24, 26, 29-32
Deep Bay Sill	El 559.0
Shallow Bay Sill	El 581.5

## 1.2 Gate Bay 17 Pertinent Data

Gate 17 – Shallow Bay Type Lower gate 11'-0" high, Upper gate 22'-6 ½" high

Gate Type – Multiple-section, Vertical Lift, Notch gate

Gate Width – 30'-10 3/8"

## 1.3 Hoist Pertinent Data

Lift System Has Varied Historically: Electric Hoist 100-ton, Automated Electric Hoist, Manual Crane Lift (currently), Automated Electric Hoist Future Capacity TBD

Whiting Gantry Crane (Crane 1) 80 ton

P & H Gantry Crane (Crane 2): 200 ton

Ederer Gantry Crane (Crane 3): 200 ton

## 1.4 Swing Rail at Bay 17 Pertinent Data

Construction 2017

Swing Rail Assembly Wt. approximately 2000 lbs.

Rail Type 175 # Rail

## 2.0 Background

Rock Island Dam is a hydroelectric dam on the Columbia River in the State of Washington. The dam was built between 1929 to 1933. Construction began in January 1930, and the dam, powerhouse, and first four operating units were turned over to Puget Sound Power & Light Company by Stone and Webster Engineering Corporation on February 1, 1933. Work on completion of the dam, powerhouse expansion and installation of six additional units by Chelan County PUD began in July 1951 and was completed on April 30, 1953. A second powerhouse was completed in 1979. The facility is located about 12 miles (19 km) downstream from the city of Wenatchee. The dam features two hydroelectric powerhouses at either end of the dam. The dam is curved at either end in plan with a straight section between with a top of parapet at El 620.00. The dam is a mass concrete gravity type. There are 31 slot spillway bays on the dam of two types: deep and shallow. There are 13 deep spillway bays and 18 shallow spillway bays. There is a fish ladder in the middle of the dam occupying bay 15. The spillway gates are multiple-section vertical lift gates. The deep bays spillway gates have three gate sections per bay – two 30'-10 3/8" wide by 22'-6 1/2" high gates and one 31'-10 3/8" wide by 11'-0 high gate. The shallow bay gates have two gate sections per bay – one 31'-0" wide by 22'-6 1/2" high gate and one 31'-0" wide by 11'-0 high gate. In addition, at nine gate bays, the top gate segment has a notch fish passage gate.

The spillway gates, which rest in slots in the dam, are operated by a variety of means, including automatic fixed hoist operation for Gate Bays 6-10, 17 (currently out of use), 19, 20, 22, 25 (out of use), and 27. The other spillway gates are manually operated with a gantry crane, including Bays 17 and 25 where the fixed hoists are not operable. There are three gantry cranes operating on the dam – the 80-ton Whiting gantry crane (Crane 1), the 200-ton P & H Gantry Crane (Crane 2), and the 200-ton Ederer Gantry Crane (Crane 3). Automatic fixed gate hoist types vary across the dam with 280-ton hoists at bays 6 and 27, 200-ton

hoists at bays 19, 20, and 22, a 190-ton hoists at bays 7, 8, 50-ton hoists at bays 9 and 10. The out of use fixed hoists at bays 17, and 25 are 100/118 tons. A view of the hoists and stanchion towers is shown below in a Photo 1.



Photo 1: Rock Island Dam Deck Supports Multiple Stanchions for Removal and Storage of Segmented Lift Gates

### 2.1 Gate Bay 17

The spillway gate in Bay 17 is a two-segment lift gate. The gates can be lifted together, or the upper gate can be lifted independently. The gates are horizontally framed girders attached to a skin plate and are of riveted construction for the upper gate and welded construction in the lower gate. The gates travel on steel wheel assemblies which ride on rails fixed by rail fasteners that are bolted to the concrete slot walls. The rails extend to 21 feet above the deck. This allows the fixed overhead hoist system, which lifts the gates from the bottom of the lower gate segment, to be safely brought to the dam roadway (deck). Alternatively, the gate assembly can be lifted from the top of the upper gate by a gantry crane. This rail system was modified on Gate 17 in July 2017 to provide a downstream “swing rail” at both stanchions. This allows the above deck downstream rails to be rotated open for removal of the gates from the deck. This feature provides the capability to achieve a full open spillway and the deck can be cleared so dam overtopping flow would not be impeded by gates at the deck level. Swing rails were added to other spillway gates with fixed hoists both before and after Gate 17 with the final fixed hoist gate modified in November 2017.

The upper and lower gates have lateral restraint bumpers, which limit the gate motion in the gate slot and the wheels have flanges on the inside edges to keep the gates aligned on the rails during lifting and

closing operations. The gates are supported by steel wheels which roll on rails affixed to the concrete piers and attached to the stanchions above the deck. The wheels revolve on fixed axles, which are cantilevered from the body of the gate. This type of end support is normally used in situations where the gate is used to control flows while under low static head, as with spillway gates.

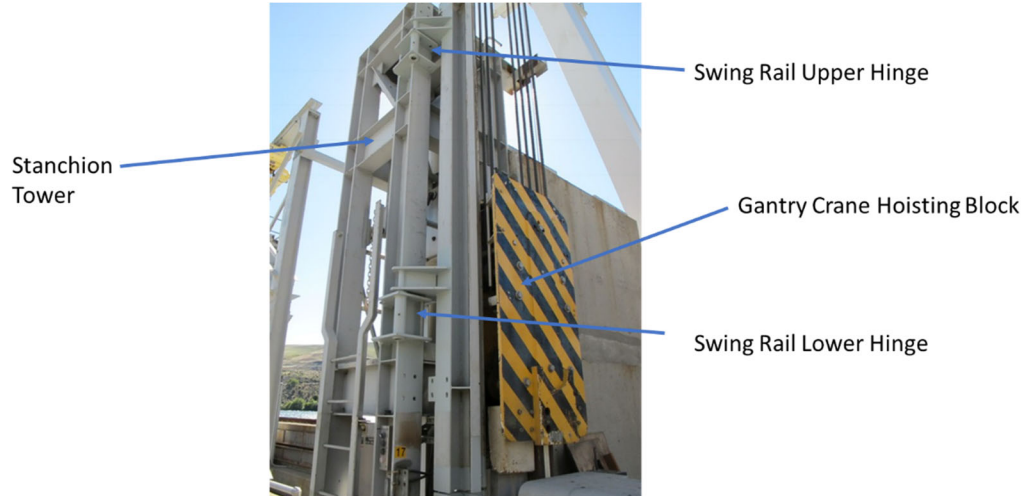

Photo 2: Gate Bay 17 South Stanchion with Swing Rail Assembly



Photo 3: Bay 17 North Swing Rail – Relocated to Storage Yard after Incident

## 2.2 Swing Rail Modification

The swing rail modification consists of a swing rail at each stanchion which can be rotated to the side of the stanchion on two hinges located at the top and bottom of the assembly so that the gate can be removed when the assembly is open. The assembly is shown in Photo 3. The swing rail is only installed on the downstream #175 rail at each stanchion. The assembly rotates on a hinge pin held by a tube welded to the stanchion. The hinge also has a locking pin, which, when in place, keeps the swing rail from swinging open. As part of the swing rail retrofit, the upstream rails are removed above the dam deck (roadway) to facilitate connecting to the gate with a gantry crane as shown in Photo 4. In the photo, the top hook for Gate 17 is also shown.

This concept of a swing rail appears to be unique to the Rock Island Dam site and is without design precedence.

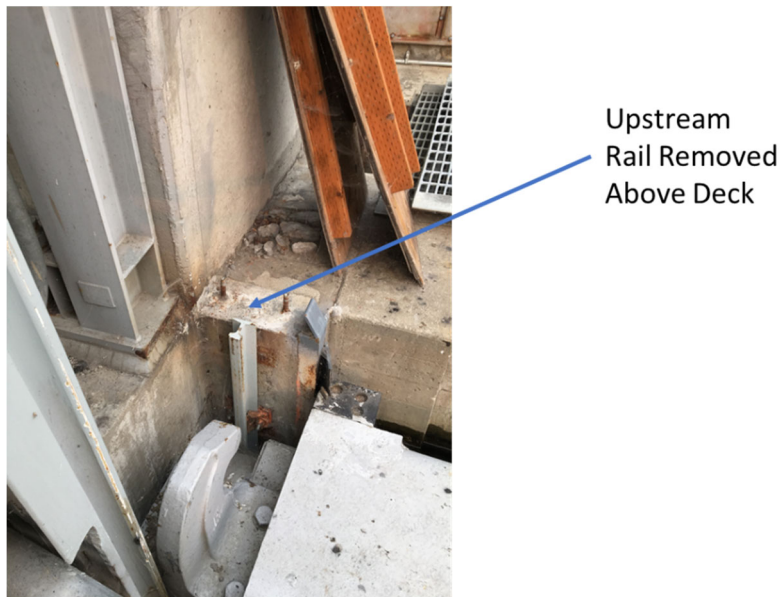

Photo 4; Gate 17 South Stanchion

Swing rail modifications have evolved over the years to accommodate the variety of in the field conditions of the rails. Currently, the swings rail assembly is modified on site to fit the dimensions of the as-built stanchion (DWG 4030-18ME-0001). The as-built alignment of the swing rail assembly with the fixed rail it replaced varies across the dam. There are variances in the vertical distance between the fixed rail and the swing rail of  $1/2''$  to  $3/4''$  and in the horizontal offset of the rails at the rail gap from  $1/16$  inch to  $3/16$  inch. For example, the gap at Gate 19 is illustrated in Photo 5 where the fixed rail and the swing rail are shown. It is evident from the photo, that there is a slight horizontal misalignment between the fixed and swing rails.

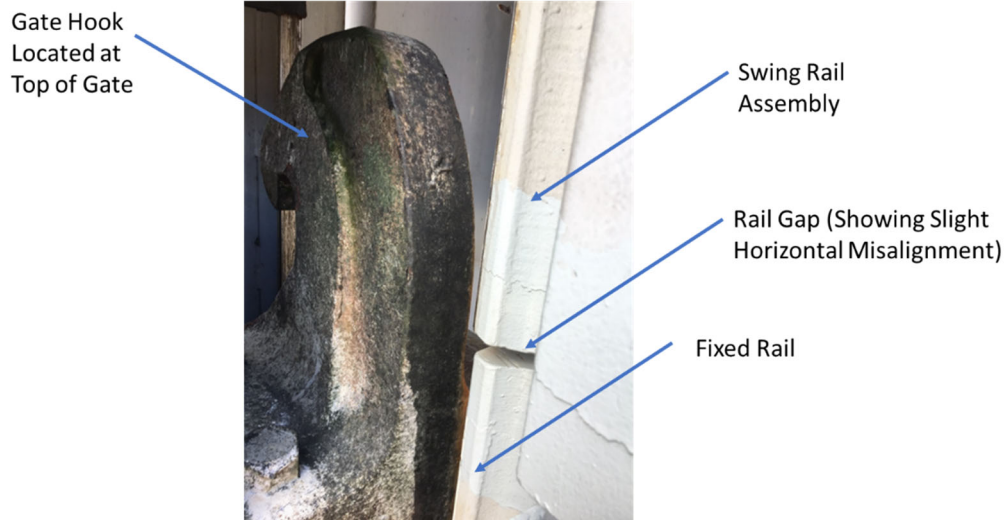

Photo 5; Rail Gap at North Stanchion of Gate Bay 19

### 3.0 History of Modifications to Gate Bay 17

Bay 17 segmental gates were designed to be lifted from the bottom. Under this configuration, although a tower or stanchion is needed to hold the hoist, it is not higher than the height of the upper gate. Actual removal of both gates under this design is not part of normal operations and is extremely difficult. The development of the swing rail, speeds up the process of removing segmental gates from the dam. The implementation of the swing rail was a cost-effective way to remove gates from the dam deck as necessitated to respond to significant flood threats and allows for gate maintenance.

#### Chronology of Relevant Construction, Operations, and Maintenance Modifications

- 1993 new Hoist and gate rail extended to 21 feet above deck. Noted on drawing 17456.11-FS-313D-3 "CUT RAIL [1 ft below the dam roadway] REMOVE END RAIL PIECES AND GRIND SMOOTH ROUGH EDGES – ALIGN NEW RAIL W/ EXIST RAIL".
- 1993 Swing Rail Assembly shown on fabrication drawing Ref DWG 9308-9371
- 2002 Ederer crane (Crane 3) constructed Ref DWG D-42230
- 2011 Swing Rail Assembly revised. Ref DWG 4030-18ME-0001
- 2012 Brake failure
- March 30, 2017 Gate jams due to hoist failure
- July 13, 2017 Swing Rail Installed in Gate Bay 17

## 4.0 Gate Bay 17 Incident Analysis

### 4.1 Relevant Operation History

On May 11, 2018 there was an uneventful FERC mandated test lift utilizing Crane 2 which occurred without incident and with no reported observation of movement by Gate 17's swing rail.

### 4.2 Relevant Maintenance History

Gate 17 experienced one significant recent maintenance event. In March 2017, the north gate hoist failed which hung the gate from the South line which eventually broke under further operation. The hoist failure resulted in concrete and rail damage at the north side (primarily the downstream side), upper gate damage to bumper, lower gate damage to latching lift eyes. During the repair it was decided to remove the fixed hoist assembly and operate the gate in manual mode with a gantry crane and, as noted above, install a swing rail assembly for removing the gates from the deck. The upstream rails, above the deck, were removed to facilitate lifting with the gantry crane. This was completed in July 2017 and Gate 17 returned to service in early August 2017, following successful testing and a full height lift using Crane 2.

### 4.3 Root Cause Analysis of June 13, 2018 Incident

As an initial matter, it is important to recognize that it is not possible in the aftermath of the June 13th incident to determine with certainty the cause of the incident. The analysis below represents the most probable cause.

The scheduled lift on June 13, 2018 was considered a normal manual lift except that Crane 3 was used instead of Crane 2. The purpose of the lift was to record hydro-dynamic forces for sizing the replacement fixed operator hoist on gate 17.

Crane 3's hoist block mechanism includes a tapered guide to allow the hoist blocks to engage a rail from above. The taper, which is composed of a front leader and a rear leader, align the hoist block to engage the rail centerline. Such a design is typical of hoist blocks on overhead cranes. The tolerances at Gate Bay 17 for the north stanchion are not known as the assembly has not been reinstalled after the incident. The south stanchion however may be representative of the precision of the installation. Photo 6 shows the south stanchion at the rail gap between the fixed rail and the swing rail. At this location the gap is relatively small, and the rail horizontal misalignment appears minimal. There is however some horizontal offset as evidenced by the abrupt change in wear along the rail flange above and below the gap. The relative horizontal offset is approximately 1/16 inch.

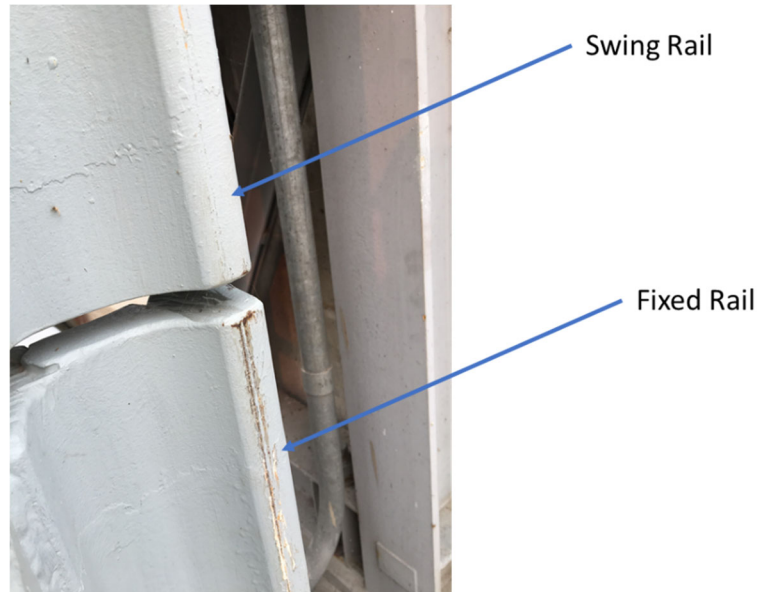

Photo 6; Gate 17 South Stanchion –Gap and Slight Misalignment Between Fixed Rail and Swing Rail

The crane hoist block leaders are tapered on the bottom, which allows them to align on rails when the block is lowered, but they are not tapered on their upper edges, refer to Photo 7. Thus, the leaders do not have an aligning feature when the hoist block is being lifted.

While Crane 3's hoist block rollers have capability to follow slight degrees of rail misalignment, the rollers' ability to track rails is limited by spacers (as shown in Photo 7). There is a range of horizontal misalignment between the swing rails and the fixed rails at the site as discussed previously. Misalignment at the rail gap between the fixed rail and swing rail is due to the precision of the swing rail modification when the hinge pivots are welded to the stanchions. The design does not include capacity for rail adjustment after the field welds are made. Further, the degree of allowable misalignment is not included in the swing rail modification drawing we were furnished by the District (DWG 4030-18ME-0001).

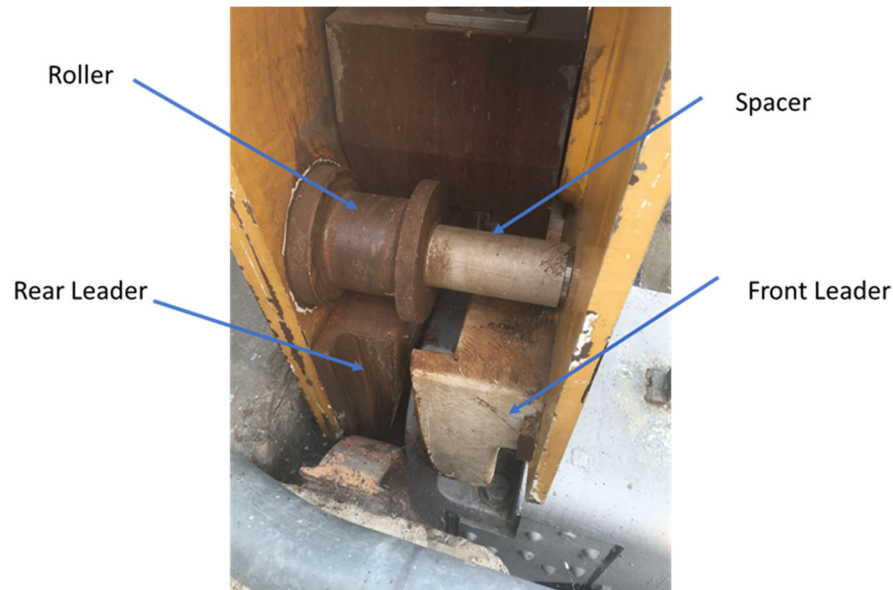

Photo 7; Hoist Block Detail of Aligning Features

Once a lift is initiated and the full load of the lift is transferred through the hoist blocks to the crane, the hoist blocks become tension-stiffened elements and tend to resist any horizontal motion due to external forces such as the rail system. If the hoist block assembly is pushed out of its equilibrium alignment by an external force or obstruction, it will tend to shift back into position when the force or obstruction is removed. This behavior was observed and recorded after the incident had occurred when Gate 17 was lowered. The north hoist block was observed to be riding out of the tracks on the lower fixed rails and when gate-lowering began to set the gate on the sill, the north hoist block shifted slightly, but noticeably, back into alignment on the lower track. This is shown below in Photo 8 shortly after the incident at Gate Bay 17. The north hoist block of Crane 3 and the guide roller have lost contact with the flange of the heavy downstream rail.



Photo 8: Gate Bay 17 North Stanchion After Incident (Gantry Crane 3 Hoist block Is Not Engaging the Downstream Fixed Rail)

It appears that during the lift, the north hoist block could not follow the north downstream rails over the gap at the junction of the swing rail with the fixed rail. Photo 8 shows the north hoist block upper roller has lost contact with the fixed rail. The hoist block's guide roller flange is riding on the rail flange bearing surface. This might be due to imprecision in the set-up of the crane over the gate, as frequently occurs in such operations, or misalignment of the North and South downstream rails.

The configuration of the hoist block, pushed upstream and off the rails, increases the tendency of the block to rotate. As the hoist block twists, the top of its leaders can catch the bottom edge of the swing rail assembly with either the top of the front leader or the top of the rear leader. Further lifting of the gate eventually unseated the swing rail assembly entirely and it fell to the dam deck ultimately striking and killing a maintenance technician.

The cause of failure is shown in Figure 1. As the hoist block cleared the top of the dam deck during the lift, and it came free of the upstream rail, the block twisted slightly rotating around the downstream rail. As the hoist block rotated, the top edge of the leaders pressed into the rail flanges and were able to catch the bottom edge of the swing rail assembly.

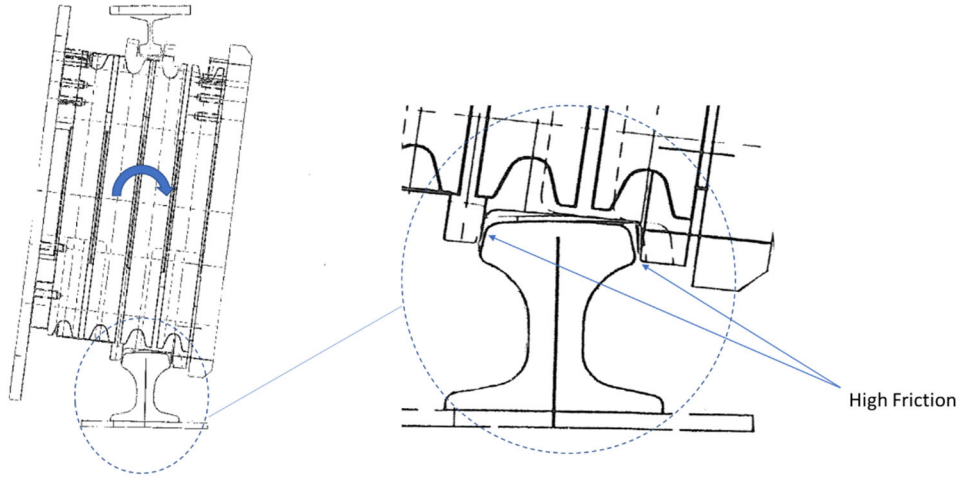

Figure 1: Pivoting Crane Block Increases Friction on Downstream Rail

The leaders at the top of the hoist block are potential catch points, as shown in Photo 9. The leaders likely lifted the bottom edge of the swing rail assembly. The potential for this scenario is increased if the crane is not aligned with sufficient precision over the lifting hook centerline and the resulting block rotation, under the high lifting load, can cause significant friction of the leaders along the rail flanges. This friction can allow the leaders to catch on and lift the exposed bottom edge of a swing rail assembly.



Potential Catch Point

Photo 9: Crane 3 North Block Potential Catch Point on the Hoist Block Leader

The failure sequence is depicted below in Figure 2. There is a slight horizontal misalignment at the rail gap between the swing rail assembly and the fixed rail at the North stanchion of gate bay 17. Although the hoist block successfully passed the gap on its way down the rail, when the lift operation starts as shown in Step 1, the leaders are pushed to one side due to the set-up of the crane above the gate. This slight offset causes the top on one of the leaders to catch the bottom edge of the swing rail assembly as the leaders, while lifting, pass over the rail gap as shown in Step 2. As the lift continues, the leader starts lifting the swing rail assembly as shown in Step 3.

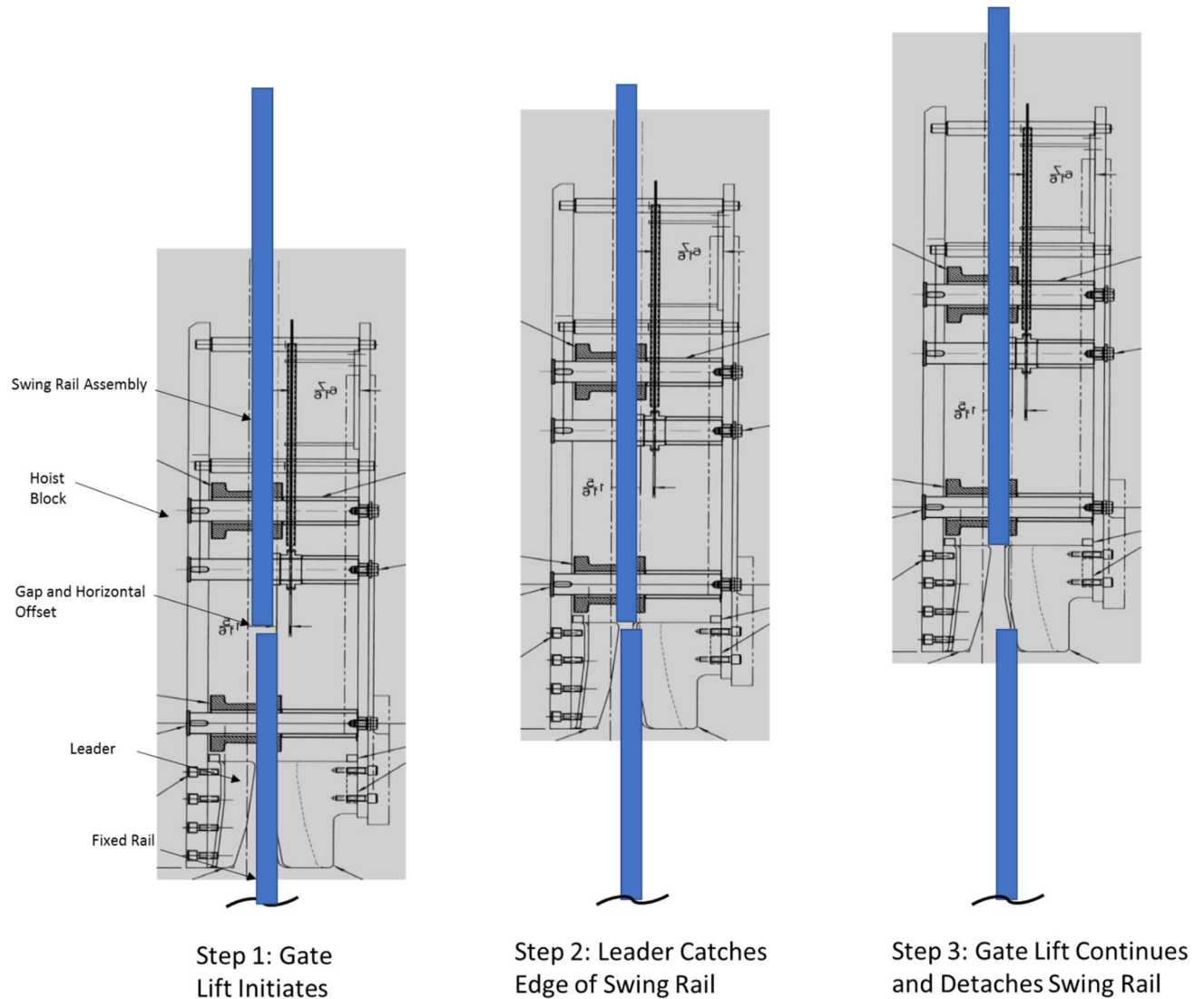

Figure 2: Root Cause Failure Sequence

## 5.0 Recommendations and Modifications for District Consideration

1. Inspect all spillway bays with swing rails. The current condition of the rails should be documented and evaluated as to whether their alignment is a concern. For reference and use during the inspection, it is recommended to refer to appropriate guidance including the United States Army Corps of Engineers (USACE) ER 1110-2-1156 SAFETY OF DAMS -POLICY AND PROCEDURES (28 October 2011). This document provides guidance on tolerable risks, periodic inspection, periodic assessment, and the continuing evaluation of dam systems. Also, USACE document ER 1110-2-8157 RESPOSIBILITY FOR HYDRAULIC STEEL STRUCTURES (15 June 2009) provides additional inspection guidance.
  - Survey key rail dimensions at spillway bays with fixed hoists at 10-foot intervals from base of the slot to the top of stanchions. This survey is recommended, at a minimum, when gate bay guide rails undergo damage.
  - Inspect wheels and lateral bumpers at spillway bays with swing rails (both upper and lower segments) for damage. This inspection is recommended after gate damage has occurred or if an incident such as the swing rail collapse occurs where wheel alignment could be a contributing factor.
  - Inspect crane rollers (Crane2 and Crane 3) to verify they are freely turning.
2. Revise swing rail design to include the design criteria shown in USACE EM 1110-2-2610 (30 Jun 13) — Mechanical and Electrical Design for Lock and Dam Operating Equipment and ETL 1110-2-584 Design of Hydraulic Steel Structures (30 June 2014). The manual (EM) and technical letter (ETL) provide guidance for sizing and designing hoists and tracks.
  - Provide hoist stall capacity to the swing rail assembly and stanchion per the USACE ETL appendix on “Lift Gates”. The swing rail as part of the safety of the dam, should be designed to withstand the hoist maximum lift load.
  - Consider the stanchions and swing rail assemblies as Hydraulic Steel Structures (HSS) per USACE design criteria and thus they should be subject to periodic inspection.
  - Specify acceptable rail tolerances on design drawings per the USACE ETL which states “The designer should assure appropriate tolerances exist in the plans and specifications to effectively fabricate and erect HSS”.
3. The following modifications to the swing rail have been or are being implemented by the PUD during the investigation for this report.
  - adding a structural bolt to hold the rail in place at the locking pin hole
  - adding a hold-down gusset plate to prevent the assembly from pulling out
  - adding a rail splice plate at the rail gap (this currently may not be under consideration due to operational concerns)
  - opening the swing rail when performing a gantry crane lift

These modifications should be analyzed based on the criteria discussed in items 1 and 2 above. Alternatively, or in addition, installation of load limiting switches on the gantry cranes to limit their maximum lift is recommended for consideration

4. The PUD should consider modifying Crane 3 block leaders to allow them to travel across rail gaps with slight misalignment. By grinding a larger radius into the top of the leader blocks, the ability of the hoist to travel across rail gaps with misaligned rails will be increased. This recommendation may be applicable to Crane 2 if it has similar geometry.
5. The PUD should also consider eliminating the need for a swing rails along the spillway altogether as this may, in the long run, prove to be the safest and most economical solution. The swing rail can be eliminated with any of the following alternatives:
  - Lift the entire segmented gate out of the slot above the dam deck (roadway), from the top of the gate. This would eliminate the need for guide rails. This will require new permanent hoists and towers.
  - Install an emergency spillway. This would eliminate the need to fully remove the gates.
  - Extend the stanchions and rail guides so the gates can be fully removed from the slots and possibly remain on top of the dam.

## **ATTACHMENT C**



Root Cause Analysis Report  
Title: CCPUD Rock Island Dam Accident  
Event Date: June 13, 2018

---

---

## **Root Cause Analysis Report**

**Chelan County Public Utility District (CCPUD)  
Rock Island Dam Accident: June 13, 2018  
Final Report  
Report Date: February 27, 2019**

**Prepared By: Frederic Lake, President, WD Associates, Inc.  
Reviewed By: Richard Steed, Director Client Support, WD Associates, Inc.  
Prepared For: Lane Powell on behalf of the Chelan County Public Utility District**

---



**Root Cause Analysis Report**  
**Title: CCPUD Rock Island Dam Accident**  
**Event Date: June 13, 2018**

---

## Contents

Glossary of Terms: .....	3
Problem Statement: .....	4
Event Description:.....	4
Extent of Condition: .....	5
Analysis: .....	7
HUMAN PERFORMANCE ANALYSIS: .....	7
BARRIER ANALYSIS .....	9
PROGRAMMATIC AND ORGANIZATIONAL ANALYSIS .....	10
EVENT AND CAUSAL FACTOR (ECF) CHART .....	11
Analysis Conclusions:.....	11
Recommendations:.....	14
Recommendations For Consideration:.....	15
Report Attachments:.....	17



## Glossary of Terms:

**Barrier:** An administrative or physical control designed to promote consistent performance and inhibit or defend against unwanted actions. Barriers either promote, prevent, discourage, detect, or compensate for unwanted actions and can be physical or administrative in form.

**Behavior:** Action by individuals and teams that can be observed and measured and are directed toward a desired result.

**Causal Factor:** An action, condition, or event that directly or indirectly influences the outcome of the incident.

**Contributing Cause:** A cause that, if corrected, would not by itself have prevented the event, however directly increased its severity or lengthened the time to discovery

**Error:** An action that *unintentionally* departs from an expected behavior.

**Error Precursor:** Unfavorable factors embedded in the job site that increases the chances of error during the performance of a specific task

**Extent of Condition:** The extent to which the condition exists, or may exist, in the same or similar equipment, procedures, or human performance.

**Knowledge-Based:** Behavior in response to an unfamiliar situation (no skill, defined rules or pattern recognizable to the individual); a problem-solving situation that relies on personal understanding and knowledge of the system, the system's present state, and the scientific principles and fundamental theory related to the system

**Latent Error:** Actions, directions, or decisions disguised to the individual that results in undetected situations or a latent condition (embedded in the organization and lying dormant) until revealed later either by an event, active errors, or accident”

**Latent Organizational Weakness:** Undetected deficiencies in organizational processes or values that create job-site conditions that either provoke error or degrade the integrity of defenses.

**Root Cause:** The fundamental causal factor(s) that, if corrected, should prevent recurrence of the accident or event.

**Skill-Based:** Behavior associated with highly practiced actions in a familiar situation usually executed from memory without significant conscious thought.

**Unwanted Action:** An action that leads to an unwanted consequence.

**Violation:** A deliberate departure from an expected behavior, policy, or procedure



## Problem Statement:

On June 13, 2018 at approximately 1445 hours, a worker at the Chelan County Public Utility District (CCPUD or the District) Rock Island (RI) Dam was struck by a split swing rail that became liberated from its hinges during lifting of Spillway Gate 17. The Worker sustained fatal injuries to his head and upper torso area.

## Event Description:

(Timeline included in Attachment A)

On June 12, 2018 a maintenance crew was assigned the task of raising and lowering selected fixed hoist gates to support gathering of load data to support a modification to the hoist assemblies for the automatic gates at the Rock Island (RI) Dam.

On June 13, 2018, at approximately 0800, a Pre-Task Planning Meeting (PTP) was held in the Powerhouse 1 (PH1) Control Room. The workers proceeded to the dam spillway to commence work as discussed. The job called for setup of a laptop computer near the Gantry 3 Allen-Bradley Load Monitoring Panel, with a connection via ethernet cable to allow data collection onto the laptop. A small table was staged to hold the laptop and the ethernet cable was connected.

The crew experienced delays with the laptop and spent the morning troubleshooting and correcting the issue. The crew then reconvened at spillway Gate 3 at approximately 1315. Between 1330 and 1345 the crew lifted Gate 3 three (3) times from the shut to fully open position then back to the shut position with no issues or anomalies noted. The crew then moved Gantry 3 to Gate 11. During the gantry movements, Mr. Bromiley walked with the laptop near the load monitoring panel and once at the new location set up the laptop table. Between 1348 and 1406, the crew lifted Gate 11 three (3) times from the shut to fully open position then back to the shut position. Between 1410 and 1428 the same process was repeated for Gate 13.

Between 1428 and 1443, the gantry crane was moved across the air gap into position at Gate 17 and lift preparations were performed. Mr. [REDACTED] noted that the locking pin on the South Swing Rail Bottom Hinge (*not the rail that became liberated*) was not in place and he called an "All-Stop" to investigate and correct the issue. He climbed up the ladder, installed the pin, and had Mr. [REDACTED] verify that the pin was inserted, and the rail was secured, by pulling on the rail to verify no movement. The job was recommenced, and Gate 17 came off its seal at 1443.



The workers were positioned as follows (See Attachment 6):

- The Foreman was operating the gantry using a “belly box” and was positioned downstream of the gate so that he could view the lift.
- Mr. [REDACTED] was located on the South End of the gate looking down into the gate slot to ensure proper rigging equipment engagement.
- Mr. [REDACTED] was located on the North End of the gate looking down into the gate slot to ensure proper rigging equipment engagement.
- Mr. Bromiley and Ms. [REDACTED] were located near each other, under the gantry crane structure downstream side, and near the load monitoring panel and were focused on ensuring the data was being gathered and was acceptable.
- Mr. [REDACTED] was located at the swing rail.

As the lift commenced, the hoist block on the North Side of the gantry crane caught and pushed up on the swing rail. The movement was not observed by the workers, and the rail continued upward motion until it became dislodged from its hinges. The rail fell to the spillway deck, then tipped over striking Mr. Bromiley.

### **Extent of Condition:**

The Extent of Condition review is performed to identify actual or potential safety and operational risks associated with the condition, or similar conditions, that resulted in the consequence, and act to mitigate that risk.

The event was triggered by the swing rail becoming liberated while lifting a fixed hoist spillway gate with a gantry crane. The consequence was driven by the worker being in the potential “line of fire” during the lifting activity.

### **Spillway Gate Operations:**

The RI Dam Spillway consists of 31 spill gates that are moved to control water flow. Eleven of the gates are “automatic” and are equipped with fixed hoists that can be operated remotely or locally. The remaining 20 gates are manual and are moved using the spillway gantry cranes.

Fixed hoist gates are equipped with swing rails of the same design as the one liberated on Gate 17 during the accident. Gate 17 and 25 are of the same design and are currently being operated manually using a gantry crane due to hoist drive failures. The remaining fixed hoist gates are also equipped with split swing rails. Therefore, the extent of condition should include all fixed hoist gates and actions should be taken to address manual lifts of these gates.



Manual gates are designed to be operated with the gantry cranes and operating instructions are contained in the spillway Operation and Maintenance Instruction (OMI). The investigative team examined the manual gate configuration and determined that configuration differences make it unlikely that a piece, such as a swing rail, would come loose during a manual lift and present a falling object hazard to personnel.

Line of Fire:

The event was consequential because personnel were in the potential line of fire and no one at the job site noticed that the rail was becoming dislodged. This event, or a similar event, can occur when personnel are in the line of fire during any lifting activity.

Other Crane Activities:

The investigative team reviewed the controls established for mobile crane operations and determined that they are reasonable to prevent this type of incident for mobile crane operations. Mobile crane lifts require lift plans, a spotter, and lift supervisory oversight that should be sufficient to prevent this type of event from occurring.

Extent of Condition Conclusion:

The extent of condition includes all lifting activities using gantry and bridge cranes. The District has taken rigorous interim actions regarding the Rock Island spillway to minimize the risk until permanent corrective actions are implemented, including:

- Access restrictions on the spillway while moving spillway gates with the Gantry Cranes
- Placing signage on the gates equipped with the split swing rail configuration stating that the swing rails must be open prior to lifting the gate
- Temporarily modifying all split swing rails with a bolt installed to prevent the rail from sliding up and becoming liberated from its hinges
- Red tagging Gates 17 and 25 (similar gate) to prevent manual lift until actions were taken to ensure personnel safety during the lift. (Gate 25 was returned to service in August 2018 after the swing rails were removed)

It is recommended that the District establish operating procedures for bridge and gantry crane lifts similar to those already in place for mobile crane operations to ensure that a “safe zone” is established, access is restricted, and a spotter or other crew member is assigned to maintain an overall lift perspective.



## Analysis:

A root cause analysis, using a rigorous and structured methodology, was performed to determine root and contributing causes and to identify actions to prevent recurrence. The investigation scope was determined, and a problem statement was developed. Pertinent data related to the event was collected, including witness statements, operating logs, engineering drawings, recordings, and photographic evidence. Interviews were conducted with the crew and with other CCPUD staff.

The following methodology was used to identify causal factors (actions, conditions, or events which directly or indirectly influence the outcome of the accident) and to determine the Root Cause (fundamental causal factor(s) that if corrected, should prevent recurrence of the accident) and Contributing Causes (cause that, if corrected, would not by itself have prevented the event, however directly increased its severity or lengthened the time to discovery):

- Human Performance Analysis to provide insight into error precursors and behaviors associated with the accident;
- Barrier Analysis to determine the barriers that were either weak or missing that allowed the event to occur;
- Programmatic and Organizational Analysis to identify weaknesses in the management system that influenced the outcome of the event; and
- Event and Causal Factor Charting to identify causal factors and to ensure a systematic review of the behaviors, programmatic, and organizational factors that led to or contributed to the event.

The swing rail and gantry crane design are evaluated by the engineering vendor, Tetra Tech. Analysis results and recommendations to prevent recurrence of the equipment failure are contained in the Tetra Tech report provided to Lane Powell. The investigative team was not able to find design drawings or engineering analysis for the swing rails installed on 11 spillway bays. It was determined, based on interviews, that the swing rails were installed on Gate 17 in July 2017 during repair activities following Gate 17's March 2017 jam.

### HUMAN PERFORMANCE ANALYSIS:

Human Performance Analysis was performed to gain understanding of the incident from the workers' perspective. Even the very best workers commit errors, and to truly understand an incident it is important to examine the task in progress when the incident occurred, any workplace factors that increased the chance of error, and any latent organizational weaknesses that allowed an error to result in a consequential event.



For the purposes of this analysis, an “error” is defined as an action that *unintentionally* departs from an expected behavior. The term “unwanted action” is used to designate actions that led to the unwanted consequence.

The analysis identified the following Unwanted Actions (UA):

UA#1: Non-essential lift personnel were in the potential line of fire

UA#2: Swing Rail vertical movement was not observed by the crew.

The unwanted actions are concluded to be errors because the actions or failures to act were not intentional or deliberate. The behaviors related to the accident did not constitute a violation of CCPUD standards.

For UA#1, the error was a knowledge-based error of omission, that arose from the absence of written procedures defining controls necessary to safely perform the intended work. In the absence of a procedure, lift plan, or formal work plan, the crew’s only alternative was to use their experience and knowledge to determine roles & responsibilities, and placement of personnel for the task. The District did not recognize the danger posed by the spilt swing rail configuration at the time of the accident.

For UA#2, the error is a skill-based error of omission, where workers are so focused on the task that they unintentionally omit the important step of monitoring for potential hazards (such as rail movement presenting a falling object hazard). This type of error is typically associated with workers who are very familiar with the task and become comfortable with risk while focused on the task at hand and become desensitized to the presence of hazards. In this situation, the crew was focused on observing the configuration of the gate in the gate slot, rather than monitoring for potential safety hazards.

The actions and behaviors associated with the accident were evaluated using the culpability decision tree adapted from Dr. James Reason’s book “Managing the Risks or Organizational Accidents.” The ultimate accident culpability is determined to be a result of an *Organizationally-Induced Error/Blameless Error*. In this case, District worker actions were performed as-intended, the consequences were not intended, and, therefore, the workers did not knowingly violate expectations. Based on interviews with other similarly qualified RI maintenance personnel, it is determined that workers with similar background, experience, training, and proficiency would have performed in the same manner (substitution test). The crew had no history of performance problems or unsafe acts.

An Error Precursor Analysis was performed for the identified Unwanted Actions. The most significant error precursors included:



**Root Cause Analysis Report**  
**Title: CCPUD Rock Island Dam Accident**  
**Event Date: June 13, 2018**

- 1) Unclear Goals, Roles, or Responsibilities - Uncertainty about the duties an individual is responsible for in a task that involves other individuals.
- 2) Lack of or Unclear Standards - Ambiguity or misunderstanding about acceptable behaviors or results.
- 3) Unexpected Equipment Condition - System or equipment status not normally encountered creating an unfamiliar situation for the individual.
- 4) Inaccurate Risk Perception - Unrecognized or inaccurate understanding of a potential consequence or danger

The incident was not the result of an unsafe act committed by the Crew or District Management. While the investigation did uncover credible evidence of prior knowledge of the risk by District personnel, that information was not formally documented or disseminated to the crew that performed the lift on June 13. Therefore, workers did not violate expectations because the risk posed by the split swing rail design was not known or anticipated by the personnel involved with task performance on June 13. Actions or omissions associated with this event are deemed to be *Latent Errors*, defined as “actions, directions, or decisions disguised to the individual that result in undetected situations or a latent condition (embedded in the organization and lying dormant) until revealed later either by an event, active errors, or accident.”

#### BARRIER ANALYSIS

Barrier Analysis was used to determine missing, weak, or ineffective (flawed) defenses that may have had an impact on the accident. The following are the key insights gained from the barrier analysis:

- 1) Management controls for gantry crane operations are missing defenses that may have precluded this accident. These include:
  - a. The Gantry Crane OMI does not contain spotter requirements or restrictions on personnel in the potential line of fire during gantry operations.
  - b. The CCPUD Safety Program does not establish requirements for use of a spotter for gantry crane operations or establishment of a “safe zone” when operating gantry cranes
  - c. There are no formal lift plan requirements (either for specific lift or generic for lifting fixed hoist gates with gantry cranes).
- 2) Management controls for fixed hoist spillway gate operations are missing defenses that may have precluded this accident. These include:



**Root Cause Analysis Report**  
**Title: CCPUD Rock Island Dam Accident**  
**Event Date: June 13, 2018**

- a. The Spillway Gate OMI does not contain requirements or a specified method or procedure for operation of fixed hoist spillway gates using a gantry crane
- b. The Spillway Gate OMI does not contain requirements to open swing rails during fixed hoist gate lifts using a gantry crane
- 3) The design of the split swing rail did not prevent upward movement or secure rail in place.
- 4) HPI implementation has not bridged the gap between the need to improve human performance and practical application of the principles.
- 5) Work planning and PTP activities did not:
  - a. Establish a "Safe Zone" to ensure workers were not in the potential line of fire (specifically workers not directly associated with gate rigging activities)
  - b. Identify crew roles and responsibilities to ensure overall perspective of the lift or assign a spotter to monitor for hazards
  - c. Establish controls to restrict personnel and traffic through the area during lifts
- 6) Assignment of the foreman to also act as crane operator (Working Foreman) interfered with overall perspective of the lift because working foreman could not effectively maintain overall view of the job and operate crane.
- 7) There is credible evidence of concerns raised in the 1990's regarding potential split swing rail hazard that were not formally documented or institutionalized in District procedures or training.

#### PROGRAMMATIC AND ORGANIZATIONAL ANALYSIS

Programmatic and organizational analysis was used to identify weaknesses in the organization and management systems that influenced the outcome of the event. Key insights (in addition to those identified above) are presented below:

- 1) Gantry lifts are not viewed as presenting sufficient risk to warrant controls such as spillway access restrictions, removal of non-lift personnel from the area, or assignment of a crew member to maintain an overall lift perspective
- 2) Supervisors and managers are not in the field with enough frequency to drive consistent conduct of PTP and risk management activities.
- 3) The three-person crew was unable to ensure an overall lift perspective or to spot for unanticipated hazards (such as falling objects). The District routinely utilizes "working foremen", which diminishes the effectiveness of supervision to maintain an overall perspective to ensure safe and correct crew performance.



**Root Cause Analysis Report**  
**Title: CCPUD Rock Island Dam Accident**  
**Event Date: June 13, 2018**

- 4) The managers and supervisors interviewed had differing expectations regarding performance of PTP's, that leads to a conclusion that there is inconsistent communication and enforcement of PTP performance expectations.
- 5) District Program Oversight and Monitoring did not provide for adequate oversight or corrective actions/learning from previous similar events:
  - a. District learning programs have not been used effectively to learn from previous issues with spillway gates. A previous fixed hoist failure and gate jam of Gate 17 in 2017 was a "near-miss" because cables impacted areas normally traversed on the spillway; however, the event was not entered into IRIS and was not evaluated.
  - b. Safety and learning metrics are predominately lagging indicators, with few indicators aimed at predicting or proactively improving performance. For example, there are no metrics for PTP quality of field implementation or the result of management observation of field activities.

#### EVENT AND CAUSAL FACTOR (ECF) CHART

Event and Causal Factor Charting was used to show the sequence of events and identify causal factors. The causal factors were then shown on a cause and effect tree to provide the line of sight from the event to the root cause. The ECF was used to support the Analysis Conclusions below.

#### **Analysis Conclusions:**

**Root Cause: Failure to promptly and formally document and, as necessary, address through training and/or operational practices the swing rail-related safety concerns.**

There is credible evidence that concerns identified by RI maintenance personnel in the 1990's, shortly after the swing rails were initially modified to the split rail design at bays 6 and 27, were orally reported to District management. Work practices were reportedly modified to address the risk of a split swing rail lifting out of its hinges resulting in a potential safety hazard at deep bays with operating fixed hoists<sup>1</sup>. However, the potential hazard and work practice changes were communicated as "tribal knowledge" and not formally documented in any training, procedures, or reporting programs (IRIS was not established at that time). This

<sup>1</sup> Bay 17 was neither a deep bay nor was its fixed hoist operational on the date of the incident, so the specific practice described as having been adopted in the mid-1990s could not have been implemented in connection with the load test lift of Gate 17 on June 13. However, had the vulnerability been documented, design or operational changes may have been made to mitigate split rail-safety related concerns on all gates provided with the split rail configuration between the mid-1990's and the time of the incident.



tribal knowledge was apparently lost during the over 20-year period between identification of the potential hazard and the time of the incident. The crew involved in this incident was not aware of the concerns or modification in the work practices that had been passed down as “tribal knowledge” to previous RI Dam workers. Personnel with that knowledge had either retired or had been transferred to other District facilities.

This is the Root Cause because it is the underlying condition that, if corrected, should have prevented the incident. If the District had taken actions to institutionalize work practices and formal processes to address concerns related to the split swing rails, the potential hazard related to the split swing rails would have presumably been remedied. Best practice to address either of these possible remedies would have resulted in either an engineering fix, or a written procedure that established protocols to protect personnel performing the gate lift.

On July 1, 2005, the District implemented the IRIS Reporting System standard that provides a protocol and structure for documenting safety concerns, ensuring that management is informed and aware of the safety concern, and tracking resolution. The swing rail safety concern would be encompassed within the current reporting threshold and would, therefore, require disposition and management review. Information gathered through interviews and data reviews would suggest that this type of concern would be reported and appropriately resolved if it were raised today. The current IRIS Standard requires documentation of this type of concern; however, the District should take action to ensure that personnel understand the reporting requirement, threshold, and gage their engagement into the reporting process. This is included in the Recommendation Table for this report.

### **Contributing Causes**

Three Contributing Causes (CC) were identified:

CC1: Job planning did not ensure adequate coordination of the gate movement for testing.

Formal job planning activities were not performed because the task was perceived as a “routine” gate lift. Pre-operation planning was conducted using a series of emails between involved personnel and conduct of the PTP.

This is a contributing cause because the gaps in job planning made the District more vulnerable to the event. Formal job planning may have identified a lower risk placement for non-lift essential personnel, equipment to minimize the risk (such as longer ethernet cord), controls to ensure non-lift essential personnel were not in the potential line of fire, crew



**Root Cause Analysis Report**  
**Title: CCPUD Rock Island Dam Accident**  
**Event Date: June 13, 2018**

requirements to ensure an overall lift perspective or someone assigned to watch the lift area for unanticipated hazards.

This is not the root cause because this factor can be explained by more fundamental factors related to identification, reporting, and institutionalizing actions to mitigate the risks documented as the root cause.

CC2: The swing rail design presented an unrecognized risk to personnel safety. (As of the date of this report, the investigative team has been unable to determine where the swing rail design originated – i.e., within or outside the District)

The design possesses a latent design weakness that was not addressed during more than 25 years of engineering, operation, and maintenance activities.

This is a contributing cause because the design made the District vulnerable to the incident. Although the design weakness was first recognized in the 1990s, it was neither formally documented nor addressed and, as a result, the risk the weakness posed was not disseminated to current RI personnel. This is not the root cause because the failure to recognize the risk posed by the design vulnerability is related to risk recognition described in the root cause.

CC3: The assignment of a three-person crew required the use of a “working foreman”.

The use of a working foreman reduced the effectiveness of supervision of the activity and resulted in no one assigned to maintain an overall perspective of the lift and its associated hazards.

This is a contributing cause because the presence of a foreman overseeing the job and maintaining an overall lift perspective had the potential to identify the need for more rigorous controls of the work area and may have detected the rail movement before it became liberated from its housing. This is not the root cause because this is explained by the risk recognition factors associated with the root cause.



Root Cause Analysis Report  
 Title: CCPUD Rock Island Dam Accident  
 Event Date: June 13, 2018

### Recommendations:

Number	Identified Cause	Recommendation
WDR1	<p>Read "Extent of Condition" Section on page 5-6 for full description.</p> <p>The extent of condition includes all lifting activities using gantry and bridge cranes.</p>	<p>Establish operating procedures for bridge and gantry crane lifts to ensure that a "safe zone" is established, access is restricted to essential personnel, and a spotter or other crew member is assigned to maintain an overall lift perspective.</p>
WDR2	<p><b>Root Cause:</b>            Failure to promptly and formally document and, as necessary, address through training and/or operational practices the swing rail-related safety concerns.</p>	<p>Conduct an independent survey or assessment of CCPUD personnel at all facilities to:</p> <ol style="list-style-type: none"> <li>1) Determine the degree of employee awareness of and engagement in the IRIS Reporting System,</li> <li>2) Assess the frequency with which employees currently document safety concerns; and</li> <li>3) Perform a data review of IRIS concerns to ensure that appropriate actions have been taken by the District to resolve and institutionalize similar safety concerns.</li> </ol> <p>Based on the results of the assessment, determine if additional actions are required to address the root cause concerns.</p>



### Recommendations For Consideration:

Number	Identified Cause	Recommendation for Consideration
<b>WDRC1</b>	<b>Root Cause:</b> Failure to promptly and formally document and, as necessary, address through training and/or operational practices the swing rail-related safety concerns.	Develop a standard lift plan for moving fixed hoist gates with gantry cranes that includes: <ul style="list-style-type: none"> <li>- Analysis of the risks associated with the lift</li> <li>- Mitigating actions for identified risks</li> <li>- Requirements to establish a “safe zone” for non-lift crew members.</li> <li>- Requirements to assign either a spotter, or a crew member with the responsibility to maintain an overall lift perspective</li> </ul>
<b>WDRC2</b>	Same as WDRC1	Revise CCPUD Safety Program requirements for gantry and bridge crane operations to: <ul style="list-style-type: none"> <li>- Establish a safe zone for all lifts;</li> <li>- Provide a designated crew member to either function as a spotter or maintain an overall lift perspective; and</li> <li>- Provide controls to restrict access by non-lift personnel.</li> </ul>
<b>WDRC3</b>	Same as WDRC1	Revise the Spillway OMI to include the following: <ul style="list-style-type: none"> <li>- Procedure for operation of fixed hoist gates using a gantry crane.</li> <li>- Actions to open the swing rails when lifting a fixed hoist gate equipped with swing rails using a gantry crane.</li> </ul>
<b>WDRC4</b>	Same as WDRC1	Develop District standards for “what good looks like” for PTP conduct. At a minimum: <ul style="list-style-type: none"> <li>- Focus on identifying and mitigating job risks</li> <li>- Provide clear attributes of a good PTP (“What good looks like”)</li> <li>- Provide expectation to validate that work-site conditions are consistent with the PTP discussion for cases where the PTP is not conducted in the work area</li> </ul>
<b>WDRC5</b>	Same as WDRC1	(All parts of this actions are required to be completed before action is closed)  1) Once the previous action has been completed (PTP Standards), gain alignment and agreement from supervisors and managers that they



**Root Cause Analysis Report**  
**Title: CCPUD Rock Island Dam Accident**  
**Event Date: June 13, 2018**

Number	Identified Cause	Recommendation for Consideration
		<p>understand and will enforce the standard with their workers.</p> <p>2) Communicate the PTP Standards to Foremen and work crews using multiple methods and media.</p> <p>3) Develop a plan to observe and reinforce worker behaviors of “what good looks like” for PTP conduct (with emphasis on risk recognition/mitigation). At a minimum, this plan should include:</p> <ul style="list-style-type: none"> <li>a. Defined field observation attributes for managers and supervisors’ use during observations</li> <li>b. Involvement of an independent Subject Matter Expert (SME) to perform paired observations and reinforce “what good looks like”</li> <li>c. Defined expectations for the number, frequency, and targeted groups for observations.</li> <li>d. Defined exit criteria for when the desired PTP behaviors are anchored in the organization and the formal observation plan is no longer warranted. This should include criteria for periodic observations to maintain behaviors.</li> </ul> <p>4) Develop metrics to track and trend results of the observations. Metrics should include indicators showing desired PTP behaviors.</p> <p>5) Conduct a check and adjust activity (assessment) to determine if desired behaviors have been anchored based on the exit criteria developed in the Plan.</p>
<b>WDRC6</b>	Same as WDRC1	Continue implementation of Human Performance Improvement (HPI) tools at the District.
<b>WDRC7</b>	<p><b>Contributing Cause 1:</b>            Job planning did not ensure adequate coordination of the</p>	<p>Develop and implement job planning requirements and standards to ensure that formal job planning is performed for jobs that:</p> <ul style="list-style-type: none"> <li>- Perform activities not addressed by OMI’s, procedures, work instructions, or lift plans;</li> </ul>



Root Cause Analysis Report  
 Title: CCPUD Rock Island Dam Accident  
 Event Date: June 13, 2018

Number	Identified Cause	Recommendation for Consideration
	gate movement for testing.	<ul style="list-style-type: none"> <li>- Require coordination of multiple work groups;</li> <li>- May impact dam operations;</li> <li>- Are not routinely performed; or</li> <li>- Present a high level of risk due to the presence or suspected presence of a known hazard (such as asbestos, harmful materials, chemicals, etc.)</li> </ul> <p>At a minimum, job planning activities should include:</p> <ol style="list-style-type: none"> <li>1) Task reviews and walkdowns to identify and mitigate hazards and risks associated with the job;</li> <li>2) Resource requirements including personnel, tools, equipment, and oversight</li> <li>3) Coordination requirements when multiple work groups are involved;</li> <li>4) Instructions for job conduct</li> </ol>
<b>WDRC8</b>	<b>Contributing Cause 2:</b> The swing rail design presented an unrecognized risk to personnel safety.	Perform the actions recommended in the Tetra Tech report or developed by the District to correct the design of the swing rails to ensure that it will not become dislodged from its supports during gate movement operations.
<b>WDRC9</b>	<b>Contributing Cause 3:</b> The assignment of a three-person crew required the use of a "working foreman".	Evaluate the practice of using working foreman and determine actions to either: <ol style="list-style-type: none"> <li>1) Discontinue its use as a normal District practice, or</li> <li>2) Provide compensatory actions to ensure adequate oversight and overall job perspective.</li> </ol> <p>One potential solution is to use a graded approach to job supervision so that higher risk jobs have a non-working foreman, while lower risk or routine work can be performed using a working foreman.</p>

### Report Attachments:

1. Diagram of the Accident Scene



**Root Cause Analysis Report**  
**Title: CCPUD Rock Island Dam Accident**  
**Event Date: June 13, 2018**

**ATTACHMENT 1: Diagram of Accident Scene**

